

**Customer**

**Supplier**

Company name  
Editor  
Phone number  
E-mail

**Fields of Application**

Water supply and booster stations  
Irrigation, overhead irrigation and draining  
Filling and emptying of tanks and containers  
Circulating of hot and cold water in HVAC systems  
Pumping of condensate  
Water circulating for swimming pools  
Sanitary and cleaning installations  
For industrial applications and public services  
Fresh water supply on ships



**Design Specification**

NMM series pumps are volute casing, single stage, end suction, monoblock type centrifugal pumps with closed impeller and mechanical seal.

Main dimensions and the nominal flow rates of the pumps comply with the DIN 24255 and EN 733 standards.

Single entry, closed impeller is hydraulically thrust compensated and dynamically balanced.

Pump and motor are separate components. Motor shaft is passed into the pump shaft for coupling. After a certain motor power, a coupling system is used between the motor shaft and pump shaft.

Maintenance is very much easier, the impeller shaft and other rotating parts being removable with no need to disconnect the suction and delivery pipes, due to back pull-out design.

Maximum interchangeability of components, identical parts can be used along various pumps of the NMM series, which greatly simplifies and reduces stock of spare parts in addition to reduced delivery times.

Single-stage centrifugal pump coupled by means of a support, to a standard asynchronous motor, closed type, with external ventilation.

NMM series are fitted with mechanical shaft seal and pump shaft is supported by motor bearings.

**Technical Data**

Suction Flange	: DN50 - DN150
Discharge Flange	: DN32 - DN125
Operating Pressure	: 10 bar
Temperature Range	: Up to 120 °C
Speed Range	: 1450 - 3500 rpm
Flow Range	: 5 - 400 m <sup>3</sup> /h
Head Range	: 4 - 105 m

**Customer**
**Supplier**

Company name  
Editor  
Phone number  
E-mail

**Operating data specification**

Pumped fluid	Water	Rated flow	m <sup>3</sup> /h
Solids		Rated head	m
Kind		Geodetic head	m
Percentage of solid content	0	Available system NPSH	m
pH value		Inlet pressure (pin)	0 kPa
Temperature	20 °C	Altitude above sea level	100 m
Density	998.3 kg/m <sup>3</sup>	Max. operating pressure	637 kPa
Kin. viscosity	1.005 mm <sup>2</sup> /s	Max. diff. pressure	637 kPa
Vapour pressure	2.34 kPa		

**Pump**

Make	MAS DAF	Impeller type	
Pump type	NMM 65-200	Impeller construction	
Frame size		Impeller Ø	
Design	End Suction Monoblock Type	Max.	218 mm
Self priming	<input checked="" type="checkbox"/> No	designed	208 mm
Speed	2940 1/min	Min.	179 mm
Stages	1	Flow	
Suction port		Nominal	115 m <sup>3</sup> /h
Pressure rating	PN16	Max.	178 m <sup>3</sup> /h
Nominal pipe size	DN80	Min.	0 m <sup>3</sup> /h
Standard	DIN	Head	
Discharge port		Nominal	55.3 m
Pressure rating	PN16	Min.	32.3 m
Nominal pipe size	DN65	Max.	65.1 m
Standard	DIN	Shut off head	65.1 m
Shaft power		NPSH3	m
Shaft power P2(Q=max.)	30.3 kW	Efficiency	%

**Motor**

Make/Type	22 KW-2900 RPM / 160L-C
Specific design	IE3 / 50 Hz / Pole pairs 1
Rated power	22 kW
Electric voltage	3~ 400 V
Speed	2950 1/min
Electric current	38 A
Frame size	160L
Degree of protection	IP 55
Type of protection	
Explosion protection	

**Coupling**

Make/Type	
Series	
Spacer length	mm
Frame size	

**Materials**

Pump		Shaft seal	AQ1EGG
Pump Casing	GJL-250 (GG25)	Material code	AQ1EGG
Impeller	GJL-250 (GG25)	Seal face	Carbon graphite antimony impregnated (A)
Shaft	A 276 Type 420 (X20Cr13)	Seat	Silicon carbide (Q1, eSiC-Q7)
		Elastomer	EPDM (E)
		Metal parts	CrNiMo steel (G)

Customer

Supplier

Company name  
Editor  
Phone number  
E-mail

Power data referred to: Water; 20°C; 998.3kg/m<sup>3</sup>; 1.005mm<sup>2</sup>/s      Sense of rotation      Clockwise from the drive end

Missing or invalid parameter (REFDIAM)

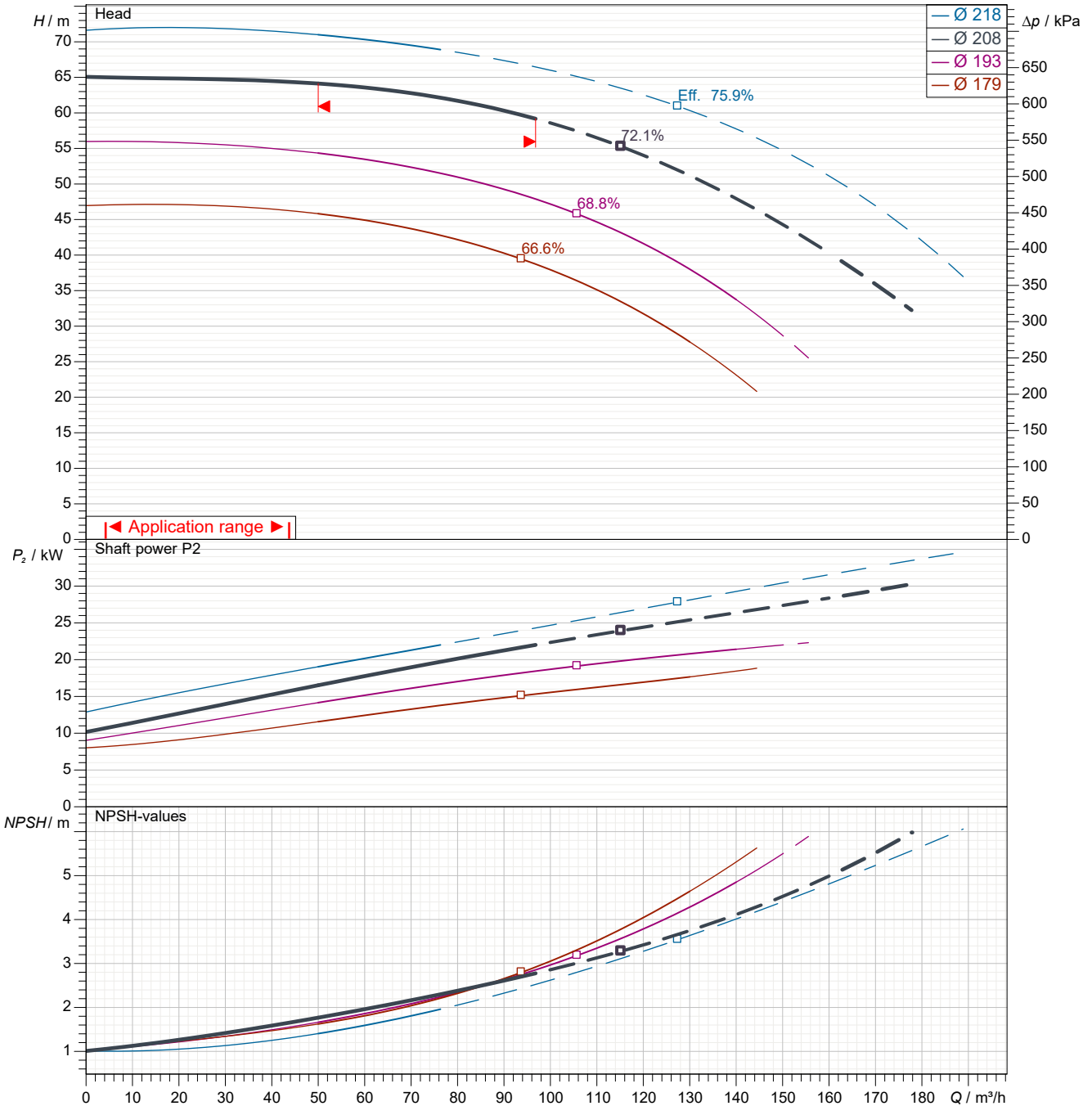

Pump curves in accordance with ISO 9906 2B

Pumped fluid	Water		Rated flow	m <sup>3</sup> /h
Temperature	20	°C	Rated head	m
Density	998.3	kg/m <sup>3</sup>	Shaft power	kW
Kin. viscosity	1.005	mm <sup>2</sup> /s	Speed	2940 1/min
Vapour pressure	2.34	kPa	NPSH3	m
Impeller Ø	208	mm	Efficiency	%

Subject to change

Projec

Issue date  
2022-04-07

Last update  
2022-04-07

Customer

Supplier

Company name  
Editor  
Phone number  
E-mail

**Performance curves**

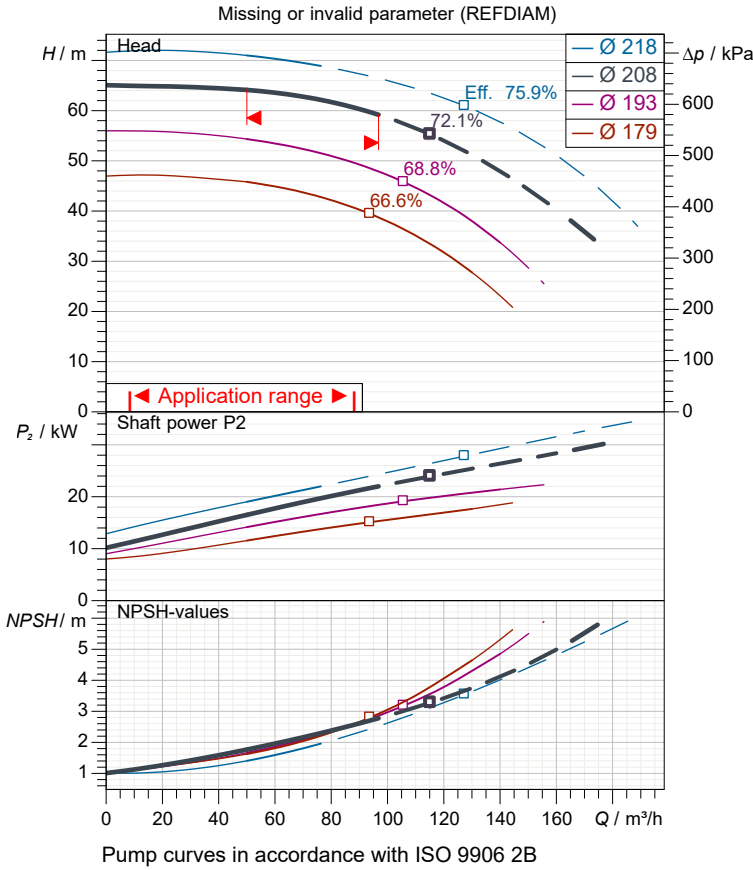

**Pump**

Make	MAS DAF
Pump type	NMM 65-200
Design	End Suction Monoblock Type
Suction port	
Pressure rating	PN16
Nominal pipe size	DN80
Standard	DIN
Discharge port	
Pressure rating	PN16
Nominal pipe size	DN65
Standard	DIN

**Operating data specification**

Pumped fluid	Water	
Temperature	20	°C
Density	998.3	kg/m <sup>3</sup>
Kin. viscosity	1.005	mm <sup>2</sup> /s
Vapour pressure	2.34	kPa
Rated flow		m <sup>3</sup> /h
Rated head		m
Shaft power		kW
Speed	2940	1/min
NPSH3		m
Efficiency		%
Impeller Ø	208	mm

**Motor**

Make/Type	22 KW-2900 RPM / 160L-C
Specific design	IE3 / 50 Hz / Pole pairs 1
Rated power	22 kW
Speed	2950 1/min
Electric voltage	3~ 400 V
Electric current	38 A
Degree of protection	IP 55

**Materials**

Shaft seal	AQ1EGG
Material code	AQ1EGG
Seal face	Carbon graphite antimony impregnated (A)
Seat	Silicon carbide (Q1, eSiC-Q7)
Elastomer	EPDM (E)
Metal parts	CrNiMo steel (G)

Pump Casing	GJL-250 (GG25)
Impeller	GJL-250 (GG25)
Shaft	A 276 Type 420 (X20Cr13)

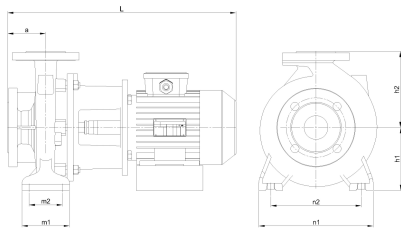

Dimensions	mm
a	100
h1	180
h2	225
L	867
m1	125
m2	95
n1	320
n2	250

Customer

Supplier

Company name  
Editor  
Phone number  
E-mail

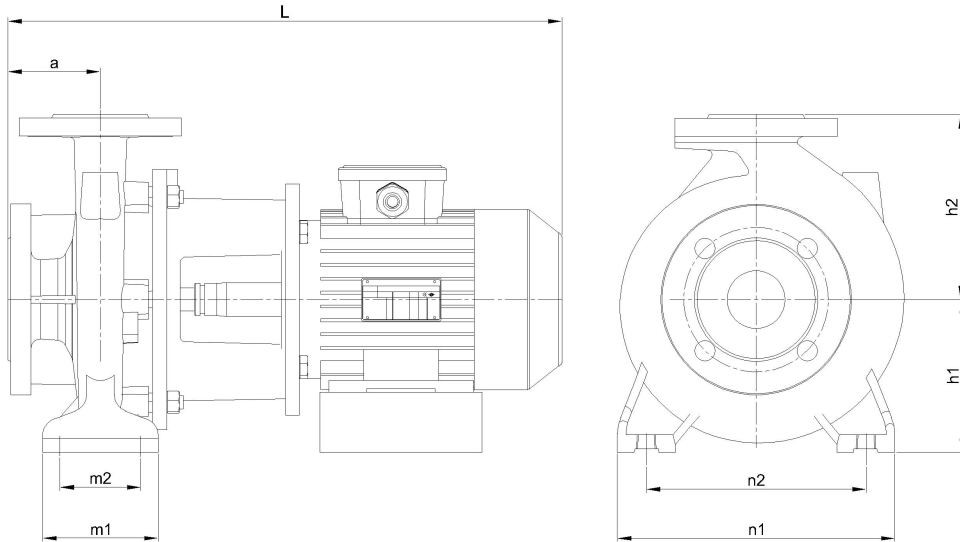

Dimensions	mm
a	100
h1	180
h2	225
L	867
m1	125
m2	95
n1	320
n2	250

Inlet / outlet	
Suction port	Discharge port
DN80	DN65
PN16	PN16

Customer

Supplier

Company name  
Editor  
Phone number  
E-mail

**motor data**

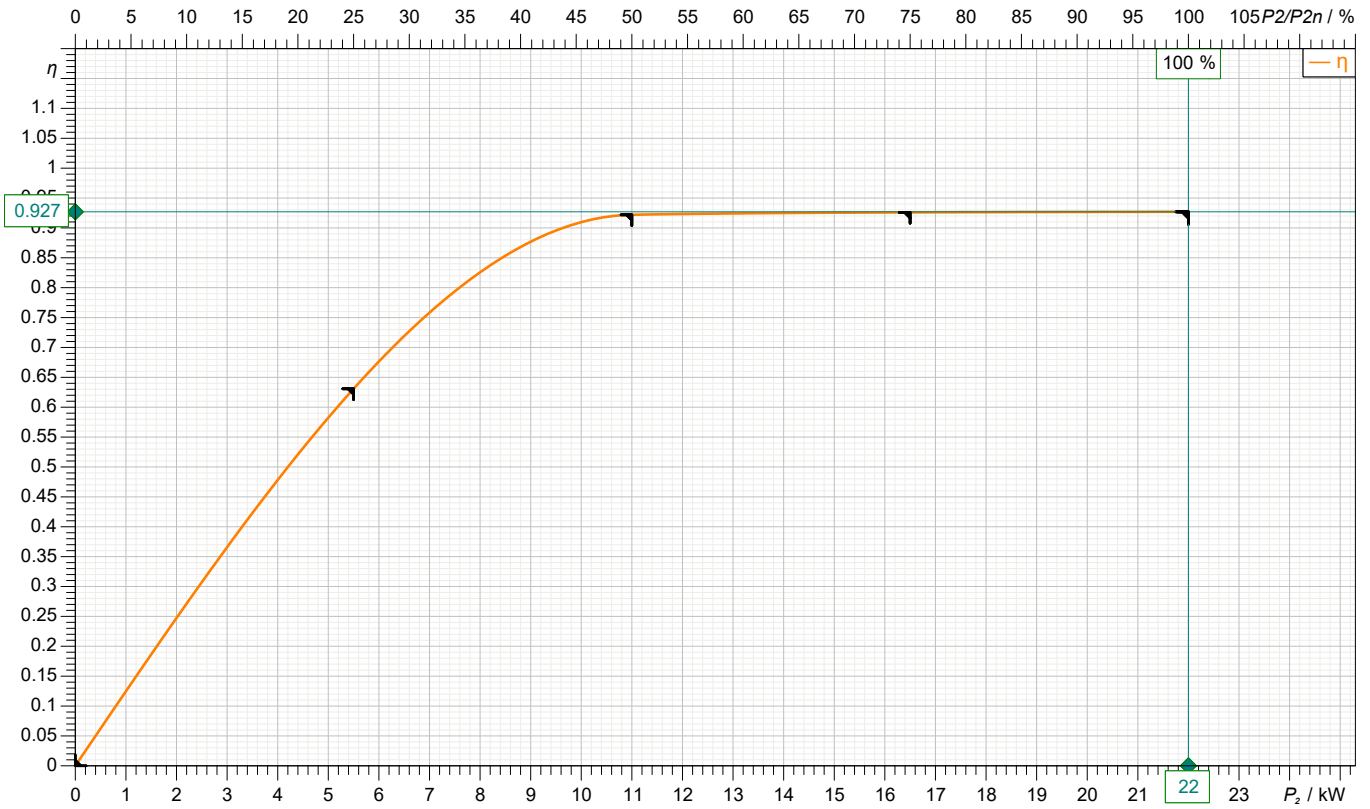

Symbol	No load	25 %	50 %	75 %	100 %	125 %
P <sub>2</sub> / kW	0	5.5	11	16.5	22	
P <sub>1</sub> / kW		8.717	11.93	17.82	23.73	
η / %	0	63.09	92.2	92.6	92.7	

**Motor**

Make/Type	22 KW-2900 RPM / 160L-C	Degree of protection	IP 55
Specific design	IE3 / 50 Hz / Pole pairs 1	Type of protection	
Rated power	22 kW	Explosion protection	
Electric voltage	3~ 400 V	Service factor	1.15
Number of poles	2	Starting current	
Speed	2950 1/min	Starting torque	
Electric current	38 A	Moment of inertia	
Power factor	0.9	No. starts per hour	
Frame size	160L	Rated torque	71.2 Nm
Efficiency class	IE3	Insulation class	F (155C°)

Customer

Supplier

Company name  
Editor  
Phone number  
E-mail

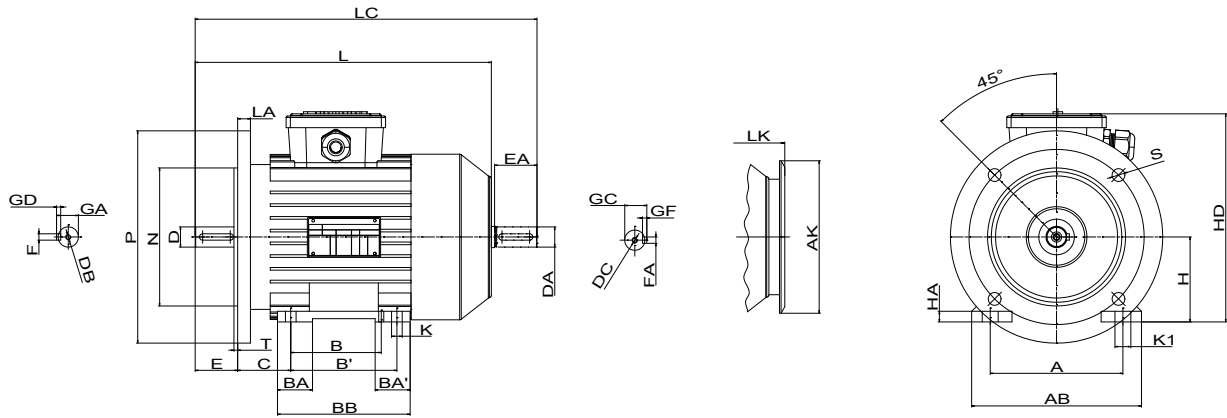

Dimensions	mm		
A	254	FxGD	12X9
AB	312	GA	45
AK	303	GC	45
B	-	H	160
B'	62	HA	22
BA	-	HD	380
BA'	304	K	15
C	108	K1	254
D	42	L	600
DA	42	LA	20
DB	M17	LC	716
DC	M17	LK	657
E	110	M	300
EA	110	N	250
FxGF	12X9	NO	4

Customer

Supplier

Company name  
Editor  
Phone number  
E-mail

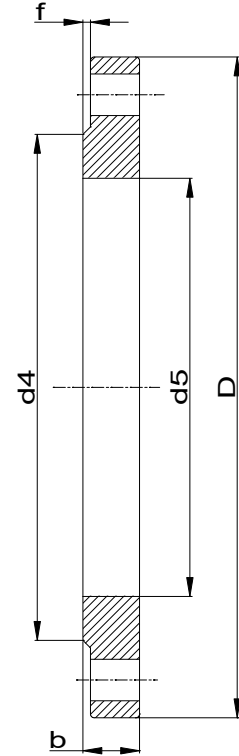
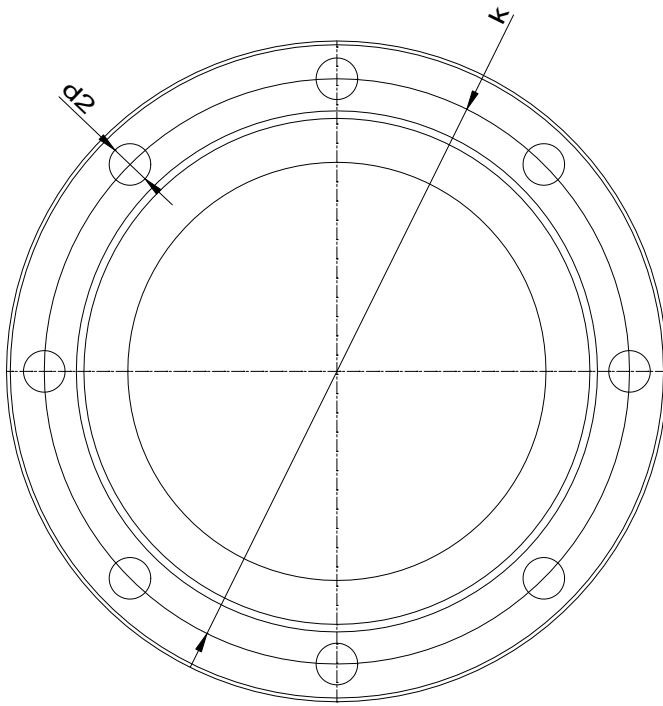

**Suction connection**

DN80  
PN16

**Discharge connection**

DN65  
PN16

Dimensions	mm
b	20
D	200
d2	18
d4	160
d5	90.5
DN	80
f	2
k	160
n	8

Dimensions	mm
b	20
D	185
d2	18
d4	122
d5	77.5
DN	65
f	2
k	145
n	8





**Spare part list**  
NMM 65-200

Revision number

Page  
9

Company name  
Editor  
Phone number  
E-mail

**Customer**

**Supplier**

**Subject to change**

Projec

Issue date  
2022-04-07

Last update  
2022-04-07



**Spare part list**  
NMM 65-200

Revision number

Page  
10

Company name  
Editor  
Phone number  
E-mail

**Customer**

**Supplier**

**Subject to change**

Projec

Issue date  
2022-04-07

Last update  
2022-04-07