

General Data

Model:	GX 50-2/110 T
Code:	2004010
Series:	GX
Weight [Kg]	25.00

Submersible eletropumps for sewage with an inbuilt macerator in the inlet

Hydraulic

Impeller Type:	Grinder
Delivery DN [mm]:	G 2"
Input DN [mm]:	-
Free Passage [mm]:	-
Impeller Ø [mm]:	140
Max Pump Efficiency [%]:	29.20
Global Efficiency [%]:	23.8
Head [m]:	12.57
Flow [m ³ /h]:	9.00

Tolerance according to ISO 9906:2012 3B2



Attention: pictures for illustrative purposes

Features

Upper Meccanical seal:	Lips seal
Lower Meccanical Seal:	Silicon carbide/ceramic/Viton
Upper Bearing:	Single raw ball bearing
Lower Bearing:	Single raw ball bearing
IP Protection:	IP68
Motor protection:	present
Humidity sensor:	not present
ATEX:	not present
Applied Paint:	Two component water-based paint
Cable Length [m]:	10
Lubricating Oil:	Q8 WF15
Oil Quantity [Kg]:	

Materials

Pump:	Cast Iron EN 1561 EN-GJL-200
Impeller:	Cast iron EN 1561 EN-GJL-200
Motor shaft:	Stainless steel AISI 420
Cooling Jacket:	Not available
Screw:	Stainless steel A2-70
Cable:	H07RN8F

Pumped Liquid

Pumped Liquid:	Light and lightly sewage
Density [Kg/dm ³]:	1.1
pH:	6-10
Temperature Range:	0-40°C

Installation

Maximum depth of immersion [m]:	20
Cooling Type:	The cooling of the motor is ensured by the surrounding liquid
Installation:	Vertical
Floating on board machine:	not present

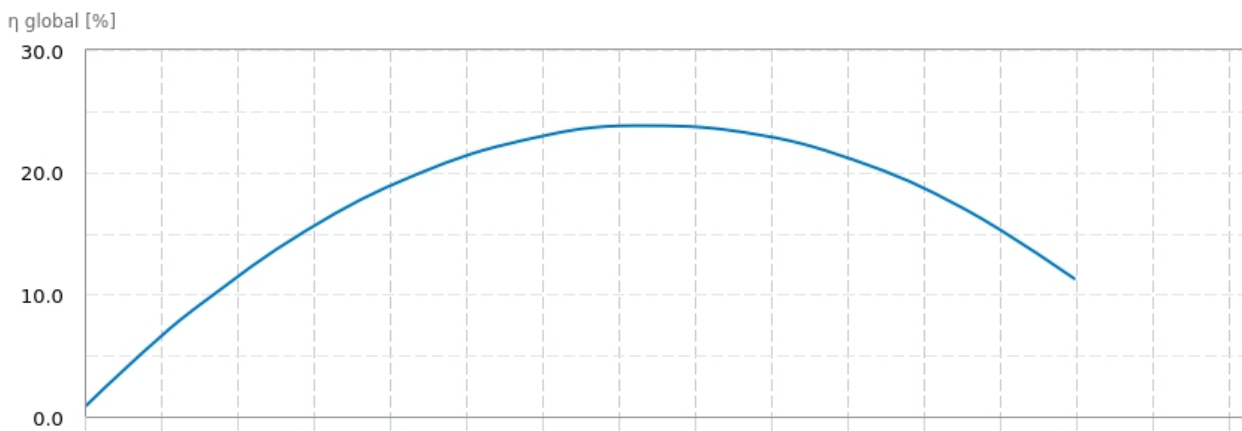
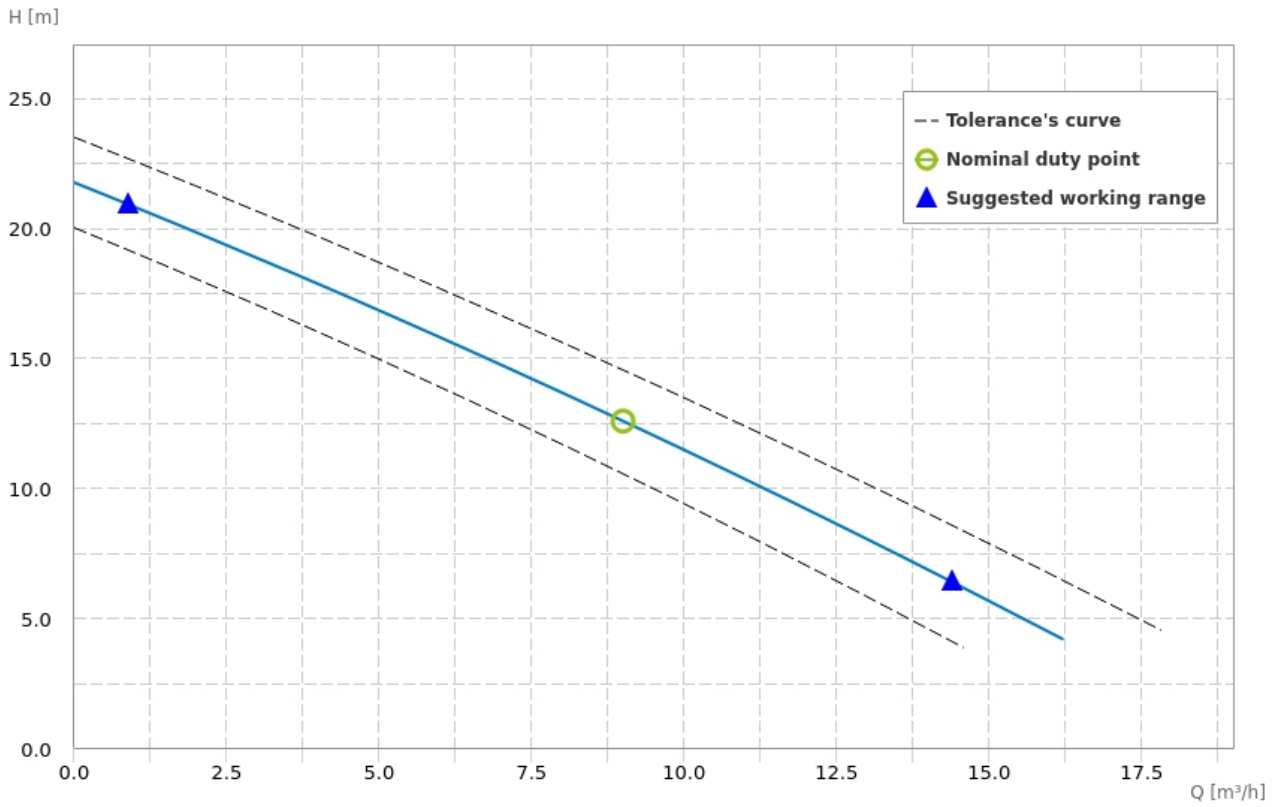

Motor

Motor code:	3520180250
Power P1 [kW]:	1.50
Power P2 [kW]:	1.10
Phases:	3
Frequency [Hz]:	50
Tension [V]:	400
Nominal current [A]:	3.1
Starting current [%]:	531.0
Power Factor:	0.81
R.P.M.:	2850
Starting:	D.O.L
Capacitor [μ F]:	-
Insulation Class:	F 155°C
Service type:	S2
Max Efficiency [%]:	81.30
Max Efficiency at full load [%]:	80.6
Efficiency at $\frac{3}{4}$ load [%]:	80.3
Efficiency at $\frac{1}{2}$ load [%]:	79.7
Efficiency class:	-

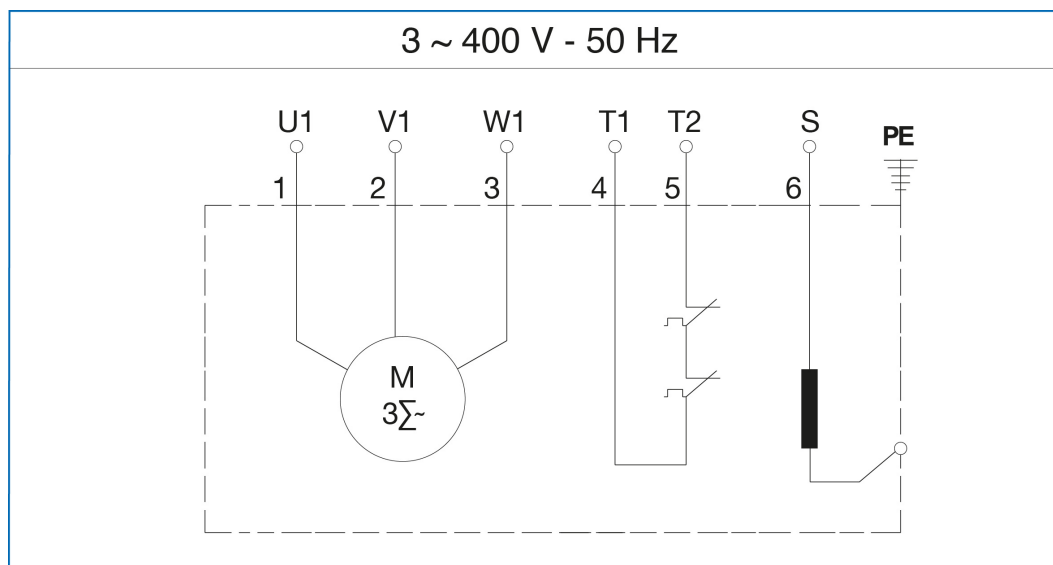
Wiring diagrams

Dimensions drawing

