

General Data

Model:	COMPATTA 3 T
Code:	2000016
Series:	Compatta
Weight [Kg]	17.50
Submersible pump for sewage with suspended solids	

Hydraulic

Impeller Type:	Vortex Impeller
Delivery DN [mm]:	G 1"1/2
Input DN [mm]:	40
Free Passage [mm]:	35
Impeller Ø [mm]:	104
Max Pump Efficiency [%]:	34.20
Global Efficiency [%]:	22.28
Head [m]:	5.94
Flow [m ³ /h]:	10.80

Tolerance according to ISO 9906:2012 3B2

Features

Upper Meccanical seal:	Lips seal
Lower Meccanical Seal:	Silicon Carbide/Ceramic/Viton
Upper Bearing:	Single raw ball bearing
Lower Bearing:	Single raw ball bearing
IP Protection:	IP68
Motor protection:	not present
Humidity sensor:	not present
ATEX:	not present
Applied Paint:	Two component water-based paint
Cable Length [m]:	10
Lubricating Oil:	-
Oil Quantity [Kg]:	-

Materials

Pump:	Cast Iron EN 1561 EN-GJL-200
Impeller:	Cast iron EN 1561 EN-GJL-200
Motor shaft:	Stainless steel AISI 420
Cooling Jacket:	Not available
Screw:	Stainless steel A2-70
Cable:	H07RN8F

Pumped Liquid

Pumped Liquid:	Sewage
Density [Kg/dm ³]:	1.1
pH:	6-10
Temperature Range:	0-40°C

Installation

Maximum depth of immersion [m]:	20
Cooling Type:	The cooling of the motor is ensured by the surrounding liquid
Installation:	Vertical/Horizontal
Floating on board machine:	not present



Attention: pictures for illustrative purposes

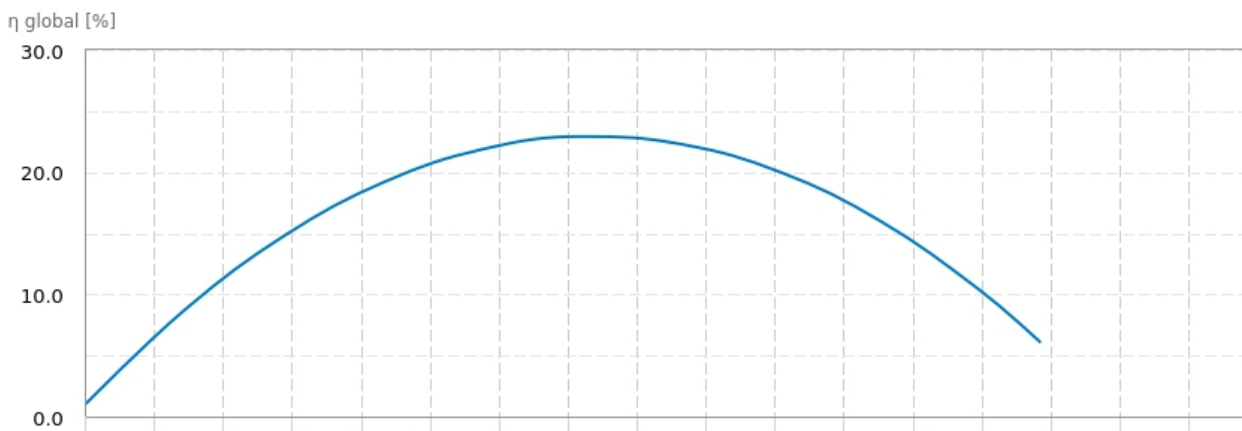
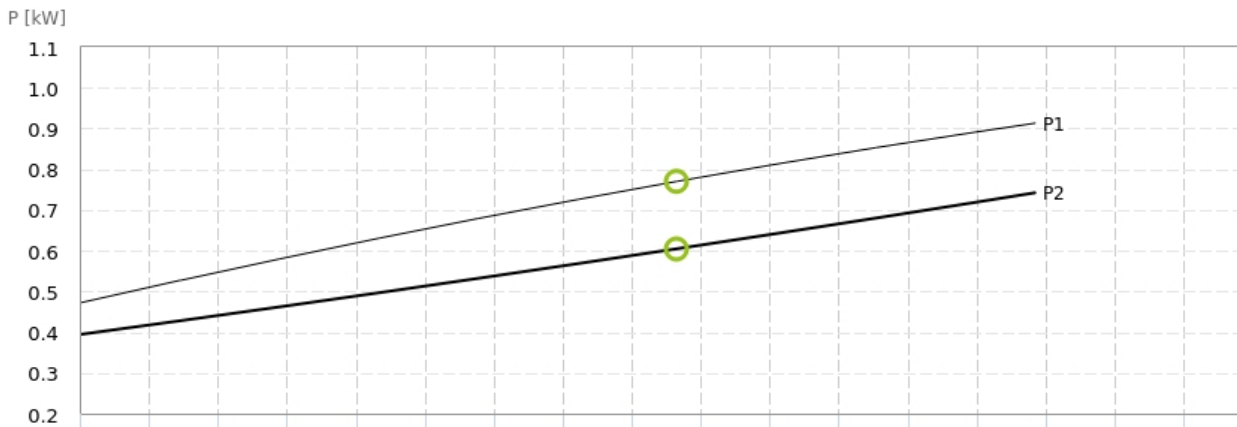
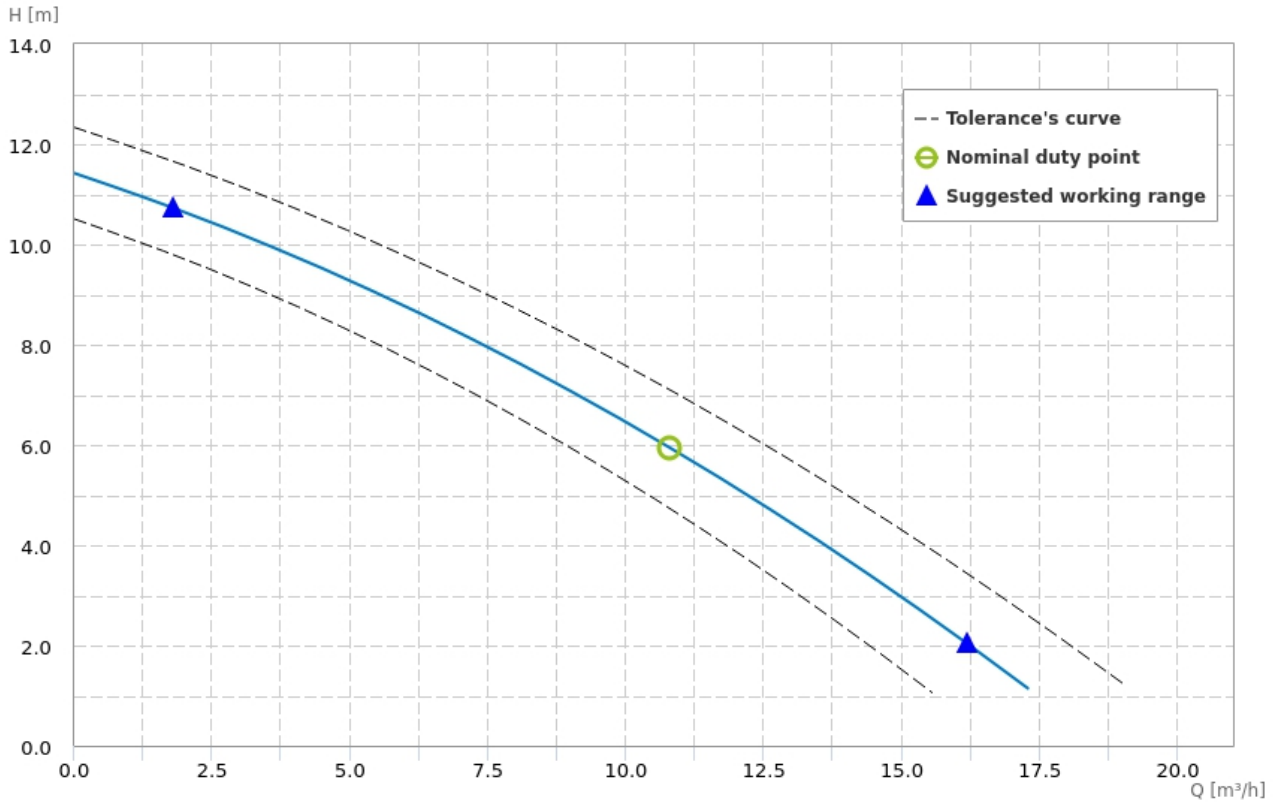



Motor

Motor code:	3520140215
Power P1 [kW]:	0.90
Power P2 [kW]:	0.75
Phases:	3
Frequency [Hz]:	50
Tension [V]:	400
Nominal current [A]:	2.0
Starting current [%]:	458.0
Power Factor:	0.67
R.P.M.:	2850
Starting:	D.O.L
Capacitor [μ F]:	-
Insulation Class:	F 155°C
Service type:	S2
Max Efficiency [%]:	72.20
Max Efficiency at full load [%]:	71.1
Efficiency at $\frac{3}{4}$ load [%]:	70.0
Efficiency at $\frac{1}{2}$ load [%]:	66.0
Efficiency class:	-

Wiring diagrams

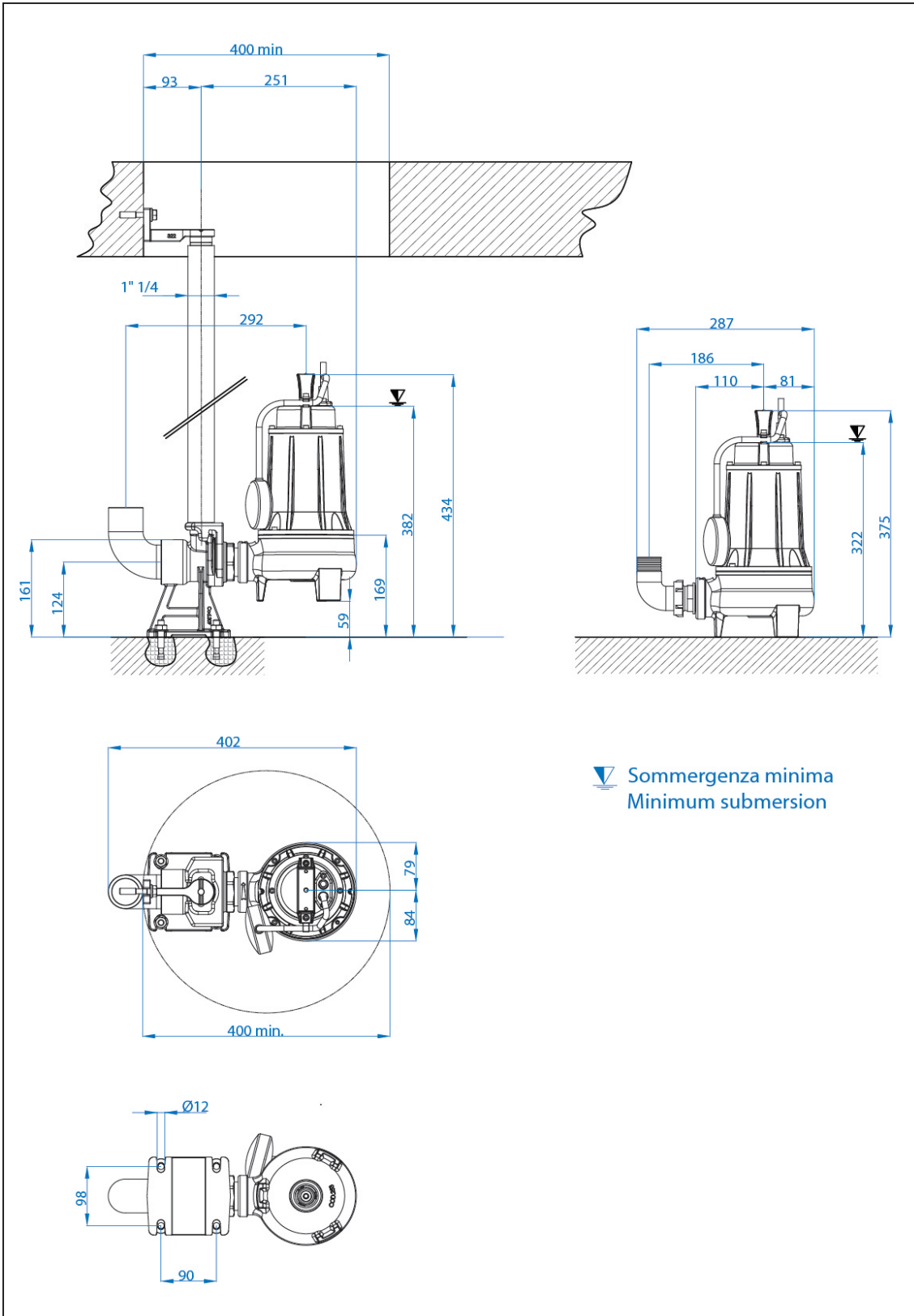
Dimensions drawing



Sommergenza minima
Minimum submersion