



Operation Manual for Incubator

IC101
IC101W

Ver. 3

● Thank you very much for purchasing this Yamato Scientific IC101/IC101W Incubator.

● Please read the “Operating Instructions” and “Warranty” before operating this unit to assure proper operation. After reading these documents, be sure to store them securely together with the “Warranty” at a handy place for future reference.

⚠ Warning: Before operating the unit, be sure to read carefully and fully understand important warnings in the operating instructions.

Yamato Scientific Co., Ltd.

This paper has been printed on recycled paper.

Table of contents

1. Safety precautions	1
Explanation of pictograms	1
List of symbols	2
Warning • Cautions	3
2. Before operating the unit	4
Precautions on installation	4
3. Names and functions of each part.....	8
Main unit	8
Operation panel	10
Heater construction and operation, features, and recovery time.....	11
Description of characters	12
4. Operating procedures.....	13
List of operation modes and functions	13
List of operation modes and functions	14
Operation mode, function setting keys and character codes.....	15
Operating procedures (fixed value operation)	16
Operating procedures (Quick auto stop operation)	17
Operating procedures (quick auto stop operation)	18
Operating procedures (auto stop operation)	19
Operating procedures (auto stop operation)	20
Operating procedures (auto start operation)	21
Operating procedures (auto start operation)	22
Useful functions (power failure compensation function)	23
Useful functions (calibration offset function)	24
Useful functions (setting key lock function)	25
Useful functions (Using the service outlet)	26
5. Handling precautions.....	27
6. Maintenance procedures.....	29
Daily inspection/maintenance	29
7. When the unit is not to be used for a long time or when disposing	30
When the unit is not to be used for a long time or when disposing	30
Notes about disposition.....	30
8. When a trouble occurs	31
Safety device and error codes	31
If a malfunction is suspected.....	32
9. After sales service and warranty	33
When requesting a repair.....	33
10. Specifications	34
11. Wiring Diagram	35
12. List of replacement parts	36
13. List of dangerous materials	37

About pictograms

A variety of pictograms are indicated in this operating instruction and on products for safe operation. Possible results from improper operation ignoring them are as follows.

Be sure to fully understand the descriptions below before proceeding to the text.

 **Warning** Indicates a situation which may result in death or serious injury (Note 1.)

 **Caution** Indicates a situation which may result in minor injury (Note 2) and property damages (Note 3.)

(Note 1) Serious injury means a wound, an electrical shock, a bone fracture or intoxication that may leave after effects or require hospitalization or outpatient visits for a long time.

(Note 2) Minor injury means a wound or an electrical shock that does not require hospitalization or outpatient visits for a long time.

(Note 3) Property damage means damage to facilities, devices and buildings or other properties.

Meanings of pictograms



This pictogram indicates a matter that encourages the user to adhere to warning ("caution" included).

Specific description of warning is indicated near this pictogram.



This pictogram indicates prohibitions

Specific prohibition is indicated near this pictogram.



This pictogram indicates matters that the user must perform

Specific instruction is indicated near this pictogram.

1.Safety precautions

List of symbols

Warning



General warnings



Danger!: High voltage



Danger!: High temperature



Danger!: Moving part



Danger!: Hazard of explosion

Caution



General cautions



Electrical shock!



Burning!



Caution for no liquid heating!



Caution for water leak!



For water only



Poisonous material

Prohibitions



General bans



Fire ban



Do not disassemble



Do not touch

Compulsions



General compulsions



Connect ground wire



Install levelly



Pull out the power plug



Regular inspection

1.Safety precautions

Warning · Cautions

Warning



Never operate the unit in an atmosphere containing flammable or explosive gas

Never operate the unit in an atmosphere containing flammable or explosive gas. Otherwise, an explosion or a fire may result since the unit is not explosion-proof. See page 37.



Be sure to connect the ground wire.

Be sure to connect the ground wire correctly. Otherwise, electrical leak may result and cause an electrical shock or a fire.



Ban on operation when an abnormality occurs

When a smoke or a unusual odor is seen or sensed, immediately turn the electric leakage breaker on the main unit off and pull out the power plug. A fire or an electrical shock may result.



Never use electrical power cords bundled.

When these are used bundled, they might overheat causing a fire.



Take care not to damage electrical power cords.

Avoid tightly bend, pull with a strong force or twist to prevent electrical power cords from damaging. A fire or an electrical shock may result.



Never use an explosive or a flammable material with this unit.

Never use an explosive material, a flammable material or a material containing them. Otherwise, an explosion or a fire may result. See page 37.



Never try to touch a hot part.

Some parts of the unit are hot during and immediately after operation. Take special care for possible burning.



Never try to disassemble or alter the unit.

Never try to disassemble or alter the unit. A malfunction, a fire or an electrical shock may result.



Caution



When a thunder is heard.

When a thunder is heard, turn the main power off immediately. A malfunction, fire or an electrical shock may result.

2. Before operating the unit

Precautions on installation



Warning

1. Be sure to connect the earth.



- Be sure to connect the earth wire (green core wire of the power cord) to the earth wire or the earth terminal to avoid an electrical shock due to earth leakage.
- Never connect the earth wire to a gas pipe or a water pipe. Otherwise, a fire may result.
- Never connect the earth wire to the earth terminal for a telephone line or to a lightning conductor. Otherwise, a fire or an electrical shock may result.
- Never use a branching outlet, which might generate heat and cause a danger.

We recommend use of a ground type outlet When a bipolar type outlet tap is used
tap.

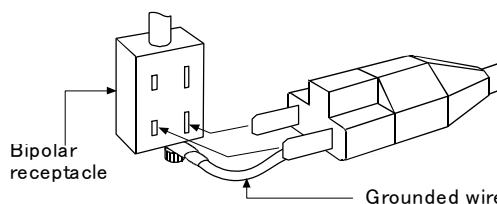
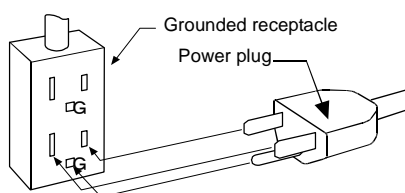

When there is no ground terminal.

In this case, class 3 grounding work is necessary and please consult your dealer or our nearest sales office.

Insert the ground adaptor included as an option, into a power plug confirming the polarity of the outlet. Connect the grounding wire (green) of the ground adaptor to the ground terminal on the power supply equipment.

2. Carefully select an installation site.



Take special care not to install the unit at a place described below:

- Uneven surfaces or dirty surfaces
- Where flammable gas or corrosive gas exists
- Where the ambient temperature is 35 °C or more
- Where temperature changes severely
- Where humidity is high
- Where subject to direct sunlight
- Where vibration is severe



Install this unit at a place with spaces shown below.

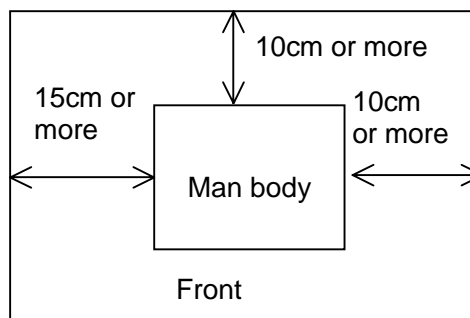

2. Before operating the unit

Precautions on installation

Warning

3. Never operate the unit in an atmosphere containing flammable or explosive gas. No flammable matters

See the section “13. List of dangerous materials” on page 37 for flammable and explosive gases.

-  Never operate the unit in an atmosphere containing flammable or explosive gas. Since the unit is not explosion-proof, an arc is discharged when switching “ON” and “OFF” and during operation and a fire or an explosion may result.



DO NOT USE



Explosive gas

Flammable gas

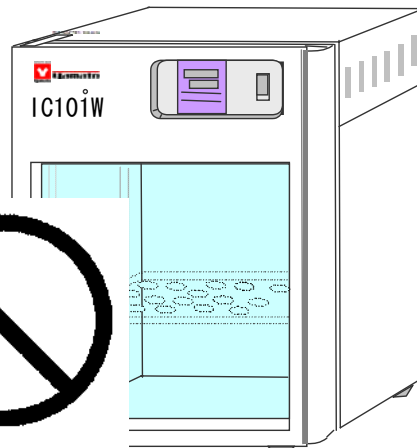

-  Do not operate the unit with flammable material inside. Otherwise, a fire may result.

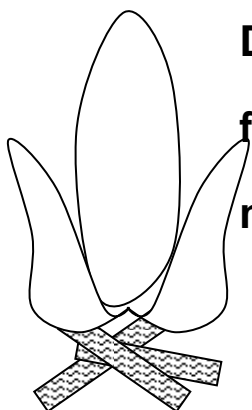







**Do not use
flammable
matters**

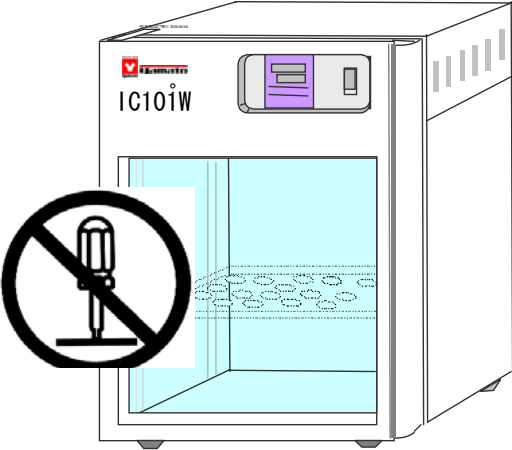
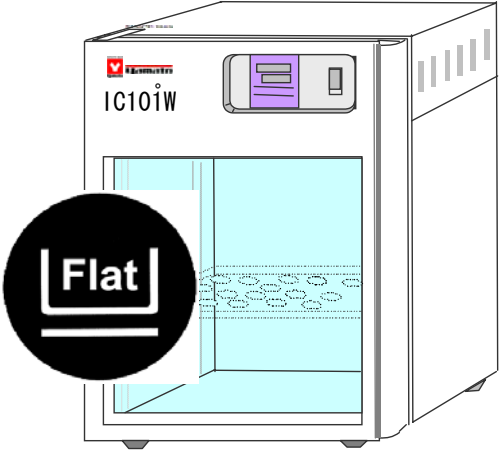

2. Before operating the unit

Precautions on installation

Warning

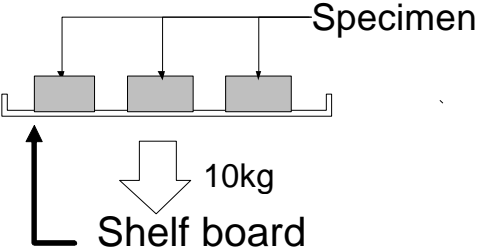
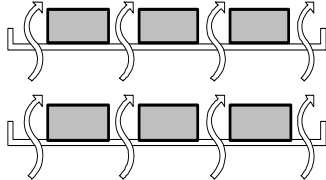
<p>4. Do not attempt to alter the unit</p>	<p>5. Install the unit on a level surface</p>
<p> The customer shall never attempt to alter the unit. Otherwise a malfunction may result.</p>	<p> Install the unit on a level surface. Otherwise unexpected troubles or a malfunction may result.</p>
	
<h4> Cautions</h4>	
<p>6. Do not put too many specimens.</p>	<p>7. Do not set too many specimens.</p>
<p> The withstand load of a shelf board is 10kg when the load is evenly distributed. Put specimens dispersed.</p>	<p> Too many specimens will prevent correct temperature control. In order to assure temperature precision, be sure to use shelf boards and put specimens dispersed, and secure at least 30% of space inside the bath.</p>
	 <p style="text-align: center;">Secure at least 30% of space</p>

2. Before operating the unit

Precautions on installation



Cautions

8. Connect the power plug to the dedicated outlet



Use an outlet that is suited to the electrical capacity.

Electrical capacity	IC101	AC100V	1.1A
	IC101W	AC100V	3.1A (While using a service outlet MAX2A)

When the unit does not start even when power is turned ON, check if main voltage is too low or if the unit is connected to the same power line as other devices. If this is the case, use a different power line from those for other devices as the power supply.

9. On installation



An earthquake or a shock may cause the unit fall over or move and personal injuries may result. We recommend exercising safety precautions including selecting an installation place where less people are passing by.

10. Installation of shelf boards or specimens



The product includes two shelf boards.

One of them is fixed at the lowest stage in the bath. Do not remove this board except when you install an optional stirrer stand with slide rail.

Set a shelf board at an appropriate position in the bath with included shelf cramps.



The bottom and side surfaces in the bath will become hot. Avoid putting specimens directly on the bottom surface or allow them to touch with the side surface.

11. Handling of a power cord



Never use electrical power cords bundled. When these are used bundled, they might overheat causing a fire.

Do not convert, forcibly bend, twist or pull the power cord. Otherwise, a fire or an electrical shock may result.

Do not place the power cord under a desk or a chair, or sand between objects to avoid it from being damaged.

Otherwise, a fire or an electrical shock may result.

Do not place the power cord close to a stove or other heat generating device. Sheath of the cord may burn and result in a fire or an electrical shock.



If the power cord should be damaged (exposure of core wire or disconnection), immediately turn the ELB off, pull out the power cord (plug) out of the power supply and ask your dealer to replace the cord. Operating the unit with a damaged power cord may cause a fire or an electrical shock.



Connect the power cord to an appropriate wall outlet.

3. Names and functions of each part

Main unit

IC101 Front view

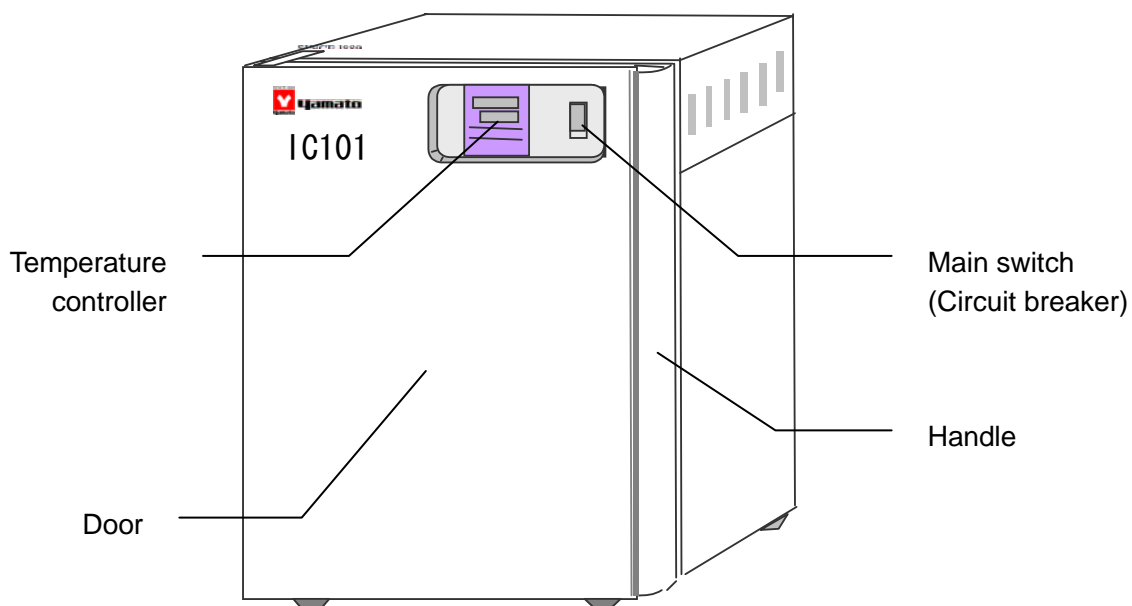

IC101 Rear view

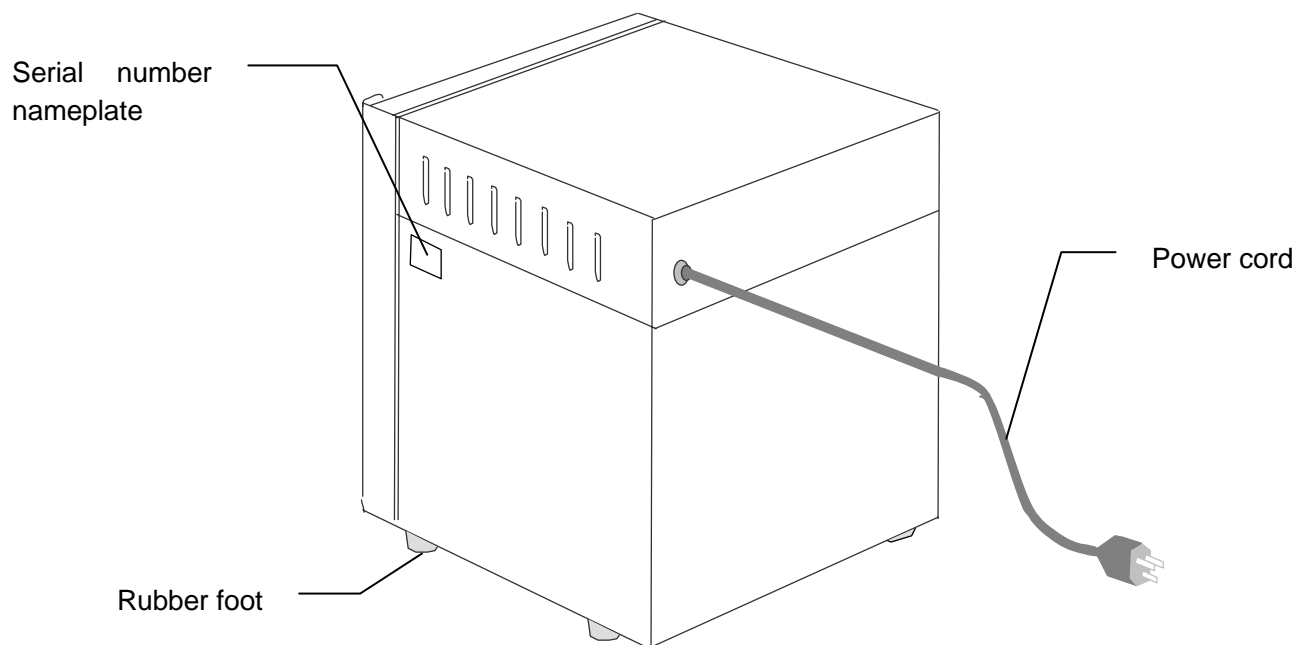

3. Names and functions of each part

Main unit

IC101W Front view

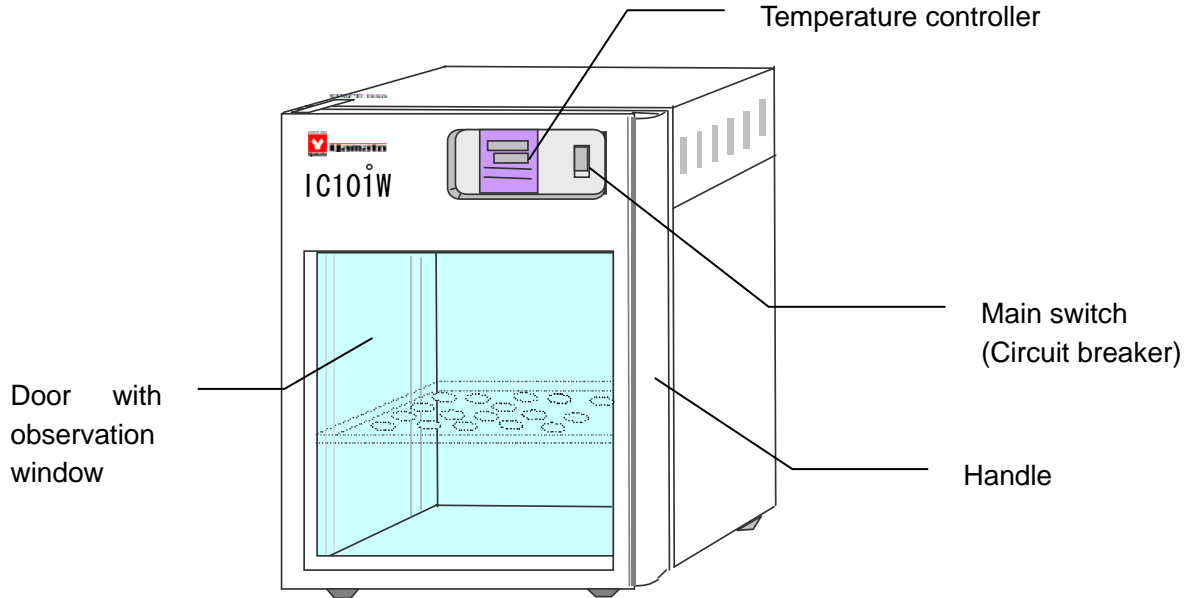

IC101W Rear view

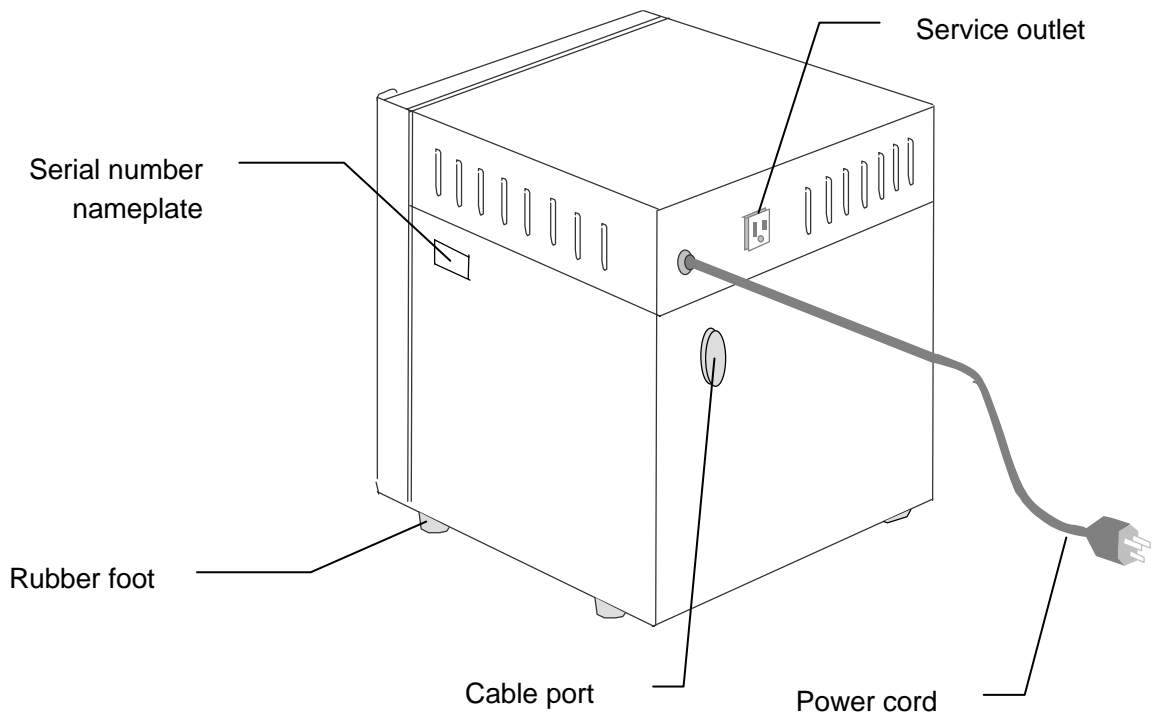

3. Names and functions of each part

Operation panel

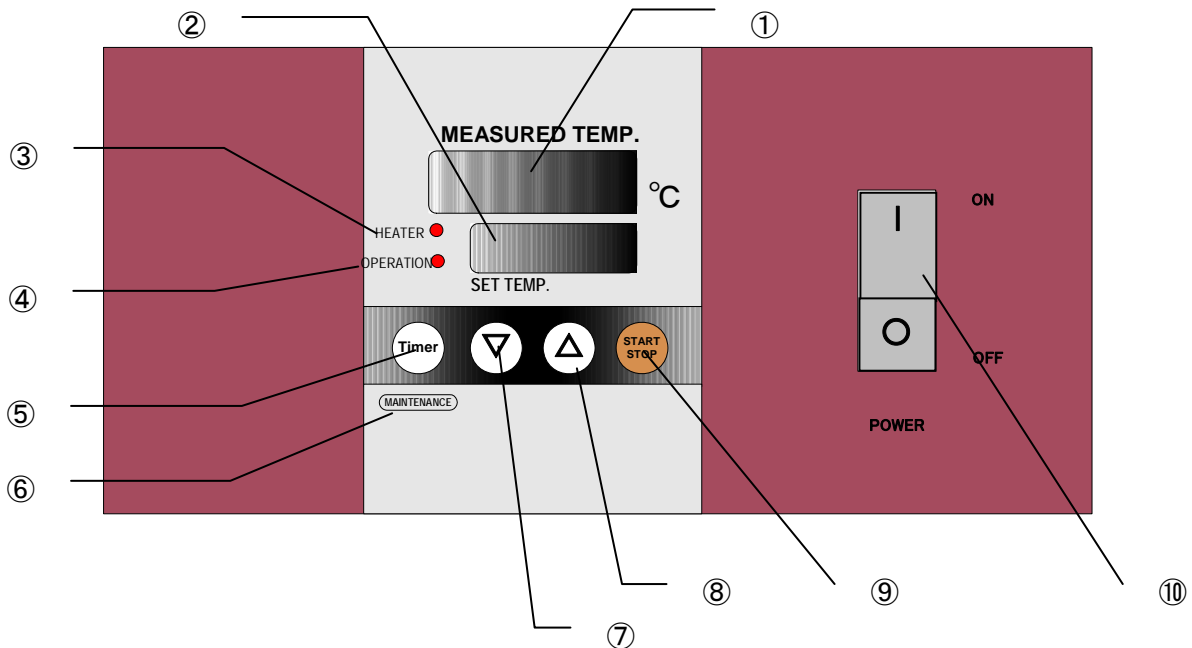

No	Name	Operation/action
①	MEASURED TEMP. indicator	Indicates the measured temperature in the bath, set characters, and error information.
②	SET TEMP. indicator	Indicates set temp., functional settings, timer settings, and remaining time of the timer.
③	HEATER lamp	Comes on while power is supplied to the heater.
④	OPERATION lamp	Stays on during fixed-setting operation; flashes during timer operation.
⑤	TIMER key	Used for timer operation of quick auto stop, auto stop, and auto start.
⑥	MAINTENANCE key	Pressing the TIMER longer enters the maintenance mode. This key is used to select and set various sub-functions.
⑦	Down key	The key is used to select a setting. Used to increment the setting.
⑧	Up key	The key is used to select a setting. Used to decrement the setting.
⑨	START/STOP key	The key is used to start or stop operation.
⑩	Power switch (Circuit breaker)	Used for turning power ON or OFF.

3. Names and functions of each part

Heater construction and operation, features, and recovery time

Heater construction and operation

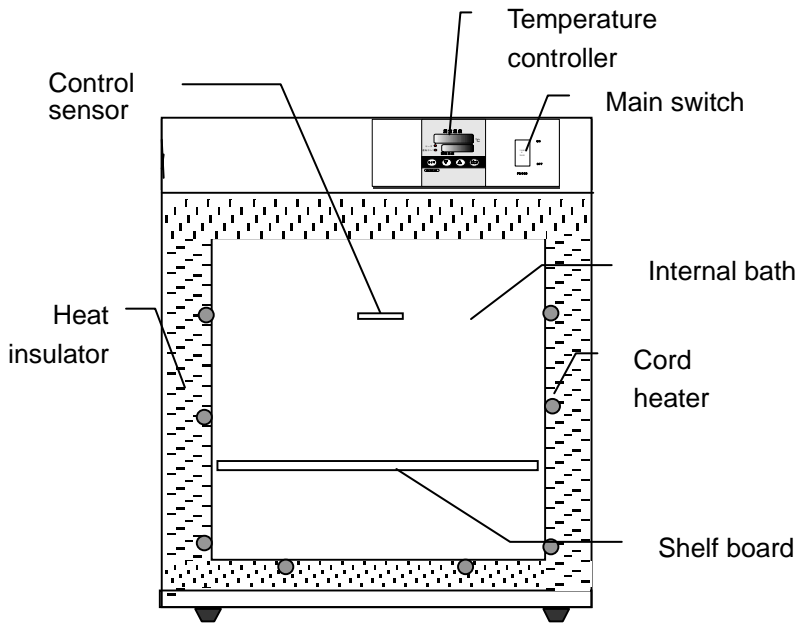

When you turn the main switch on and press the start key of temperature controller, the cord heater starts heating to warm air inside the bath.

The temperature in the bath is controlled with the temperature controller and the control sensor and becomes stable at the set temperature.

Characteristics of the model IC101/IC101W

The internal wall heating system of this product can keep temperature in the bath at a certain level with higher precision and has advantages such as specimens are not likely to dry like the air jacket system when compared with a system that uses direct air blasting and circulation.

Since models IC101 and IC101W detect internal bath wall temperature with the control sensor and control and display that temperature with the temperature controller, these have a characteristic that displayed temperature remains relatively stable even when temperature in the internal bath changes tentatively during temperature rise or from open/close of the door.

Above all, a symptom that the temperature controller does not show any temperature changes even when the temperature inside the bath shall be low immediately after opening or closing of the door is one of the characteristics of this internal bath wall heating system.

Temperature recovery time after opening/closing of the door of models IC101 and IC101W

The temperature will recover in about three to four minutes depending on the environmental temperature or amount of specimen.

(Testing condition : Door open time: 30 sec. Environmental temp.: 23°C)

Functions of the model IC101W

You can install a small stirrer or other devices in the bath of the model IC101. The power cord of a small stirrer can be connected using the cable port and the service outlet (Max. capacity: 2A) on the rear of the unit.

In this case, care must be taken for possible heating at the small stirrer in the bath. Devices that generate heat will influence proper temperature control of the incubator and therefore may be inappropriate for continued operation for a long time.



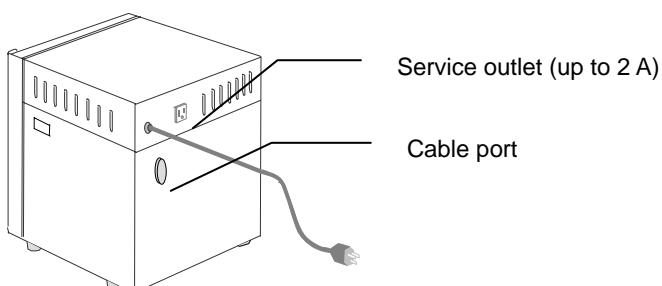



IC101W

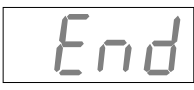

3. Names and functions of parts

Description of characters

Character codes used for the controller will be described below.

Character codes	Descriptor	Name	Application
	AStP	Auto Stop setting	Used for setting quick auto stop or auto stop operation.
	AStR	Auto Start setting	Used for setting auto start operation.
	End	Time up	Displayed when auto stop timer operation finishes. See P.17 and 19.
	Pon	Power failure compensation setting	You can select whether operation shall continue automatically when recovered from a power failure or operation shall remain stopped. See P.23.
	cAL	Calibration offset setting	Used for inputting a calibration offset temperature. See P.24 "Using the calibration offset function".
	Lock	Key lock of a setting	Locks keys to prevent changes of settings. See P.25.

※For operation modes and function character codes, see P.15 "Operation mode, function setting keys and character codes".

4. Operating procedures

List of operation modes and functions

Operation modes of this unit are as follows.

No.	Name	Description	Page
1	Fixed value operation	Operates continuously at the set temperature from start to stop of operation. After turning the main switch ON(I), use the ▼▲ keys to set the temperature. Press the START/STOP key to start operation and press the START/STOP key again to stop operation.	P.16
2	Quick auto stop operation	Used to “stop operation after several hours in the middle of operation”. Press the TIMER key during fixed value operation and select ASEP . You can set a time until operation stops. Select ASEP and set a time using the ▼▲ keys. Press the START/STOP key to start quick auto stop operation, the timer starts in the middle of operation to automatically stop operation after the set time.	P.17
3	Auto stop operation	Used to “set auto stop before starting operation”. First set a temperature with the ▼▲ keys. Then press the TIMER key to select ASEP and set a time you want with the ▼▲ keys. Press the START/STOP key to start auto stop operation.	P.19
4	Auto start operation ※	Used to “start auto start automatically after certain hours”. First set a temperature with the ▼▲ keys. Then press the TIMER key to select ASEr and set a time you want with the ▼▲ keys. Press the START/STOP key to start auto start operation.	P.21
<p>※You cannot switch the operation mode to 3 auto stop operation nor 4 auto start operation while the unit is in operation. First stop operation when you want to change the operation mode.</p>			

4. Operating procedures

List of operation modes and functions

Operation functions of the unit are as follows.

No.	Name	Description	Page
1	Overheat prevention function	<p>Automatic overheat prevention function :</p> <p>The function is set to activate automatically (automatically return) at a temperature 6°C above that in the bath when it has risen together with the unit set temperature.</p> <p>Overheat preventive device :</p> <p>A bimetal overheat preventive device of manual recovery type is installed.</p> <p>If the overheat preventive device has activated, the unit will stop and will not recover until the recovery button of the device is pressed. (Manual recovery)</p> <p>Call for service when the overheat preventive device is activated.</p>	—
2	Power failure compensation function	<p>When a power failed during operation, operation resumes at the state immediately before the power failure. (The unit may remain stopped in the timer operation mode.)</p> <p>If you want to keep operation stopped when recovering from a power failure, cancel the power failure compensation function (OFF).</p>	P.23
3	Calibration offset function	<p>The calibration offset function is a function that compensates errors by 1 °C between the set temperature and the controlled temperature (indicated temperature) when the temperature in the bath is controlled to a value different from the set temperature.</p> <p>Compensation can be made for plus or minus side.</p>	P.24
4	Setting lock function	<p>This function locks the set status currently in operation.</p> <p>You can set or cancel the function with the SUB MENU key.</p>	P.25
5	Service outlet (Model IC101W only)	<p>This is a service outlet useful to use a small stirrer. Run the power cord through the cable port on the rear of the main unit. The maximum capacity is 2A.</p>	P.26

1. Customer cannot change the setting of the item 1.
2. Functions in the items 2, 3, and 4 can be set using the maintenance function (MAINTENANCE) key.

4. Operating procedures

Operation mode, function setting keys and character codes

Operation modes and functions require the following key operations and character codes below for setting.

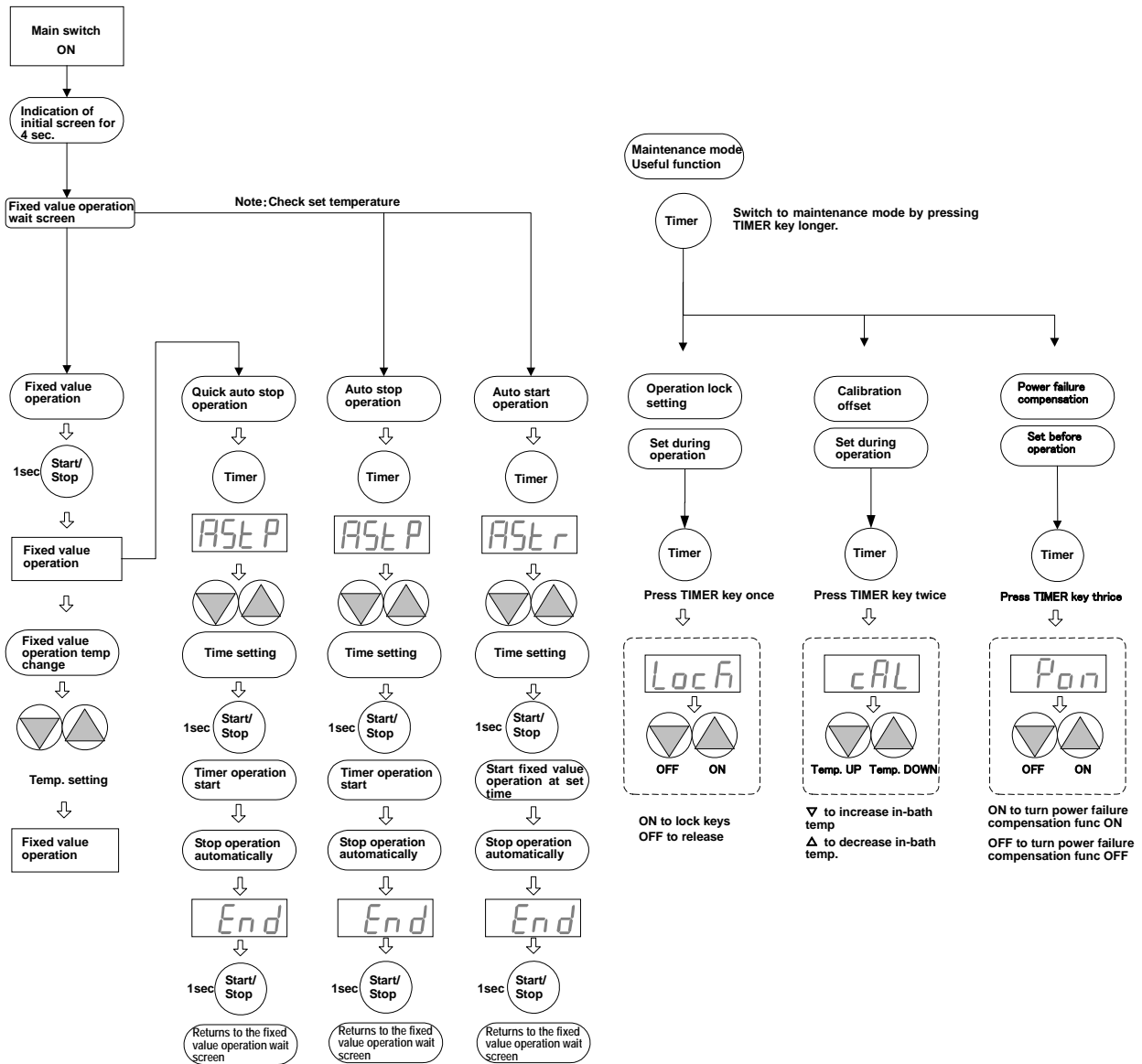

4. Operating procedures

Operating procedures (fixed value operation)

Procedures for fixed value operation

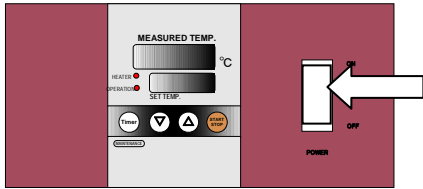

1. Turn the main switch on. (Turn the switch to “ I ”.)

Turning the switch on will display the initial values for about four seconds, then the screen will change to the initial setting screen and indicators show the current in-bath temperature and the last set temperature.

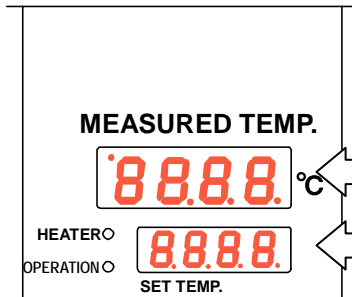

MEASURED TEMP. screen : Displays the current temperature in the bath

SET TEMP. screen : Displays the last set temperature

2. Setting the temperature

Set the temperature you want using the ▼▲ keys.

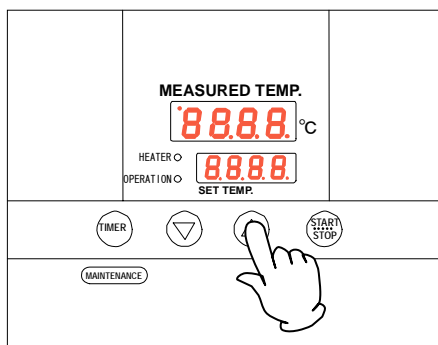

3. Starting operation

Press the **START/STOP** key longer.

The fixed value operation will start and the operation lamp and the heater lamp will come on.

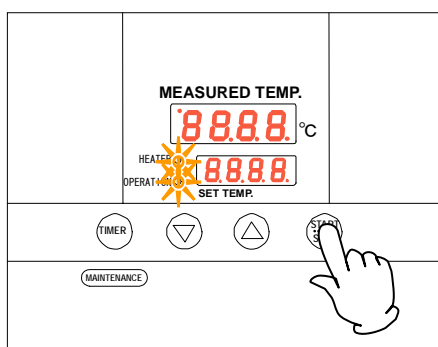

4. Stopping operation

Press the **START/STOP** key longer.

The operation will stop, the operation lamp will go off and the screen will change to the initial setting screen.

Changing the temperature

You can change the set temperature by simply pressing the ▼▲ keys.

Pressing the ▼▲ keys during operation immediately brings you to the setting mode where you can change the temperature.

After setting a new temperature, wait a while until the new temperature will be active and then the screen returns to the previous one.

4. Operating procedures

Operating procedures (Quick auto stop operation)

This is used to “stop operation automatically after several hours in the middle of the fixed value operation”.

The quick auto stop operation allows setting of auto stop timer during operation.

How to start auto stop operation

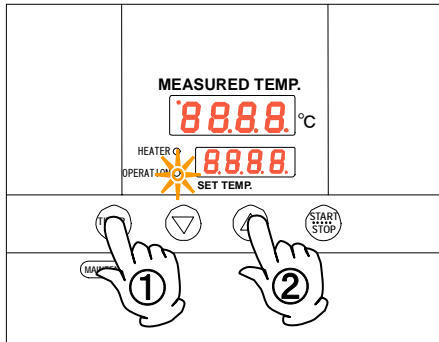

1. Setting time before stop during fixed value operation

① Confirm that the operation lamp is on, which indicates the unit is in operation.

Press the **TIMER** key.

The character AstP **85EP** that indicates the auto stop operation mode appears in the MEASURED TEMP. screen and the set time flashes in the SET TEMP. screen.

② Use the **▼▲** keys to set the time you want.

About the timer function

The maximum settable time of the timer is 999 hours 50 minutes.

You can set time in the unit of minutes up to 99 hours 59 minutes.

Time of 100 hours or longer shall be set in the unit of 10 minutes.

You can continuously change the set time and find the time you want quickly by keeping the **▼▲** keys pressed. To fine adjust the time, press the **▼▲** keys for one digit at a time.

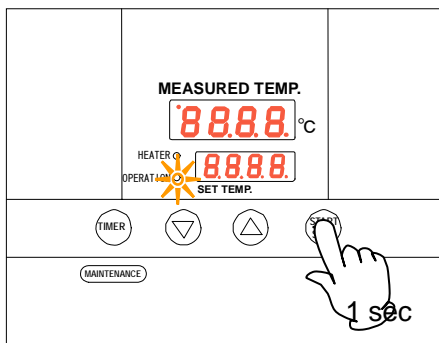

2. Starting the timer operation

When you have set the time you want, press the **START/STOP** key again while it is flashing.

The operation lamp will flash and timer operation will start.

Note : Timer counting starts when the temperature in the bath reaches the set temperature.

When the timer starts counting, the SET TEMP. screen will switch to the remaining time indication.

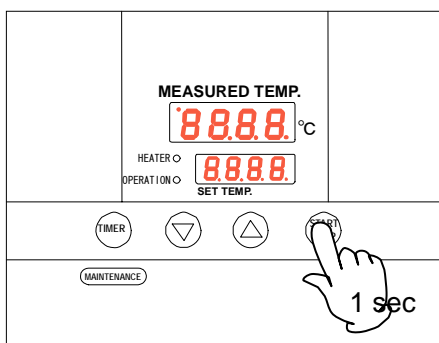

3. Stopping/finishing the timer operation

When the set time has passed, the timer will stop automatically but the character End **End** flashes in the set temperature indicator to indicate that operation has finished.

To return to the initial setting screen, press the **START/STOP** key longer for about one second to finish the timer operation mode.

The screen will return to the initial setting screen.

4. Operating procedures

Operating procedures (quick auto stop operation)

To change the set temperature or the set time

Pressing the ▼▲ keys during operation immediately brings you to the setting mode where you can change the temperature.

Pressing the **TIMER** key during operation immediately brings you to the setting mode where you can change the set time.

In this case, you need to set a time obtained by adding time that has already passed to time you want to add.

After you have changed time, press the **START/STOP** key to finish.

The remaining time indication  indicates count down while its dot is flashing.

When the dot stays on, it indicates the wait status (temperature is increasing or decreasing to the set temperature) during which timer count is stopped.

4. Operating procedures

Operating procedures (auto stop operation)

The timer is set from the start of fixed value operation and the operation is automatically stopped when the set temperature comes.

How to start auto stop operation

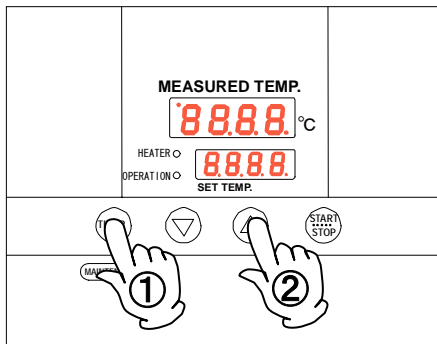

1. Setting the stop time

① Confirm that the temperature you want is set and then press the **TIMER** key.

The character **AStP** that indicates the auto stop operation appears in the MEASURED TEMP. and the set time flashes in the SET TEMP screen.

② Use the **▼▲** keys to set the time you want.

About the timer function

The maximum settable time of the timer is 999 hours 50 minutes.

You can set time in the unit of minutes up to 99 hours 59 minutes.

Time of 100 hours or longer shall be set in the unit of 10 minutes.

You can continuously change the set time and find the time you want quickly by keeping the **▼▲** keys pressed. To fine adjust the time, press the **▼▲** keys for one digit at a time.

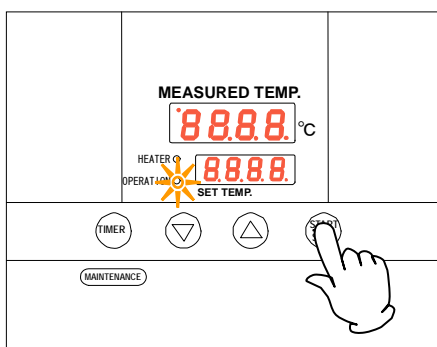

2. Starting the timer operation

When you have set the time you want, press the **START/STOP** key longer for about one second. Press the **START/STOP** key longer for about one second.

The operation lamp flashes and the timer operation starts.

Note : Timer counting starts when the temperature in the bath reaches the set temperature.

When the timer starts counting, the SET TEMP screen will switch to the remaining time indication.

3. Stopping/finishing the timer operation

When the set time has passed, the unit will stop operation automatically.

The character **End** flashes in the set temperature indicator to indicate that operation has finished.

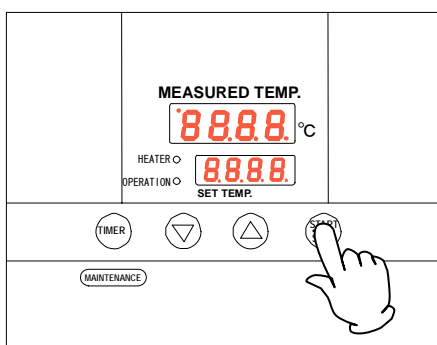

Press the **START/STOP** key longer for about one second to finish the timer operation mode. The screen will switch to the initial setting screen.

4. Operating procedures

Operating procedures (auto stop operation)

To change the set temperature or the set time Pressing the ▼▲ keys during operation immediately brings you to the setting mode where you can change the temperature.

Pressing the TIMER key during operation immediately brings you to the setting mode where you can change the set time.

In this case, you need to set a time obtained by adding time that has already passed to time you want to add.

The remaining time indication 1.30 indicates count down while its dot is flashing.

When the dot stays on, it indicates the wait status (temperature is increasing or decreasing to the set temperature) during which timer count is stopped.

4. Operating procedures

Operating procedures (auto start operation)

The mode starts operation automatically after the time set with the timer has passed.

Note that the operation will not stop automatically but must be stopped manually in this mode.

To start auto start operation

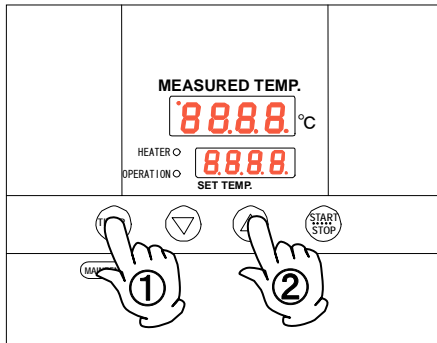

1. Setting the operation start time

① Confirm that the temperature you want has been set and press the **TIMER** key.

The character **AStr** that indicates the auto start operation appears in the MEASURED TEMP. screen and the set temperature flashes in the SET TEMP. screen.

② Use the **▼▲** keys to set the time you want.

About the timer function

The maximum settable time of the timer is 999 hours 50 minutes.

You can set time in the unit of minutes up to 99 hours 59 minutes.

Time of 100 hours or longer shall be set in the unit of 10 minutes.

You can continuously change the set time and find the time you want quickly by keeping the **▼▲** keys pressed. To fine adjust the time, press the **▼▲** keys for one digit at a time.

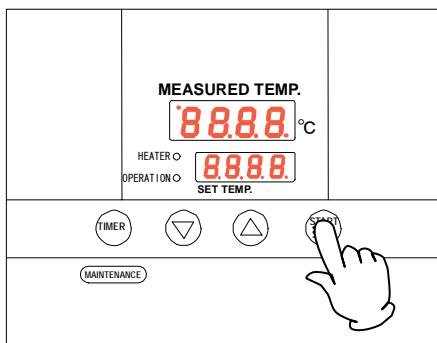

2. Starting the timer operation

When you have set the time you want, press the **START/STOP** key longer for about one second while it is flashing.

Timer counting starts when the **START/STOP** key is pressed.

The MEASURED TEMP. screen switches indication from the set time to the remaining time.

Operation starts automatically when the set time comes and the operation lamp will come on.

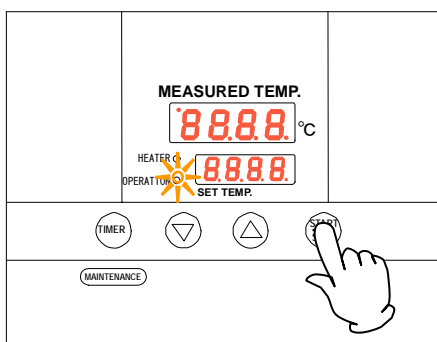

3. Stopping/finishing the timer operation

To stop operation, press the **START/STOP** key longer for about one second to finish the timer operation mode. The screen will switch to the initial setting screen.

4. Operating procedures

Operating procedures (auto start operation)

To change the set temperature or the set time

If you want to change the set temperature or the set time during operation, press the **TIMER** key during operation and set the temperature or time for auto start operation using the ▼▲ keys.

However, to change the set time, you need to set a time obtained by adding time that has already passed to time you want to add.

Note : You cannot change time once the auto start time has passed and operation has started. Since the operation mode is fixed value, first stop operation using the **START/STOP** key and make settings from the beginning.

4. Operating procedures

Useful functions (power failure compensation function)

When a power failure occurs in the middle of operation, the unit resumes operation in the state immediately before the power failure after recovering from the power failure.

(The unit may remain stopped in the case of timer operation.)

If you want to keep the unit stopped when recovering from a power failure, release the power failure compensation function (OFF).

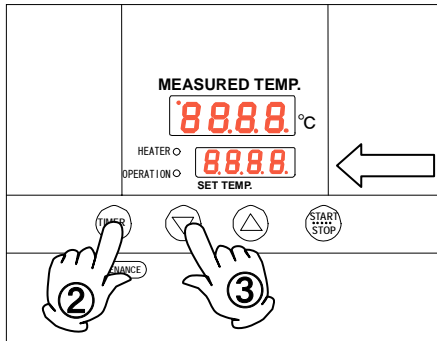

- ① Operate the unit with the initial screen status.
- ② Press the **TIMER** key longer to switch to the MAINTENANCE menu mode. (You are already in the MAINTENANCE menu mode if LOCK **LoCh** indication appears.)
Press the **TIMER** key several times to select the character Pon **Pon** that indicates the power failure compensation function.
- ③ Turn “on” in the MEASURED TEMP. screen to “oFF” using the **▼** key and you have finished setting.

4. Operating procedures

Useful functions (calibration offset function)

Using the calibration offset function

The calibration offset function is a function that compensates differences that may be generated between the temperature in the bath and the set temperature.

This function can make parallel compensation to the plus or minus side for the entire temperature range. You can set/release using the **MAINTENANCE** key.

The offset is set at "0" at the time of shipping from the factory.

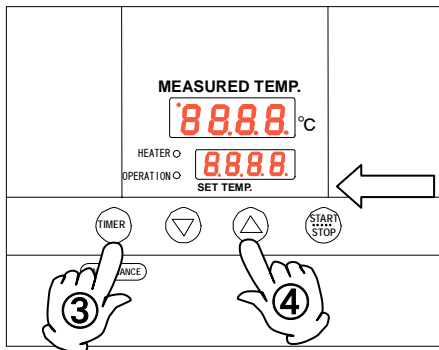
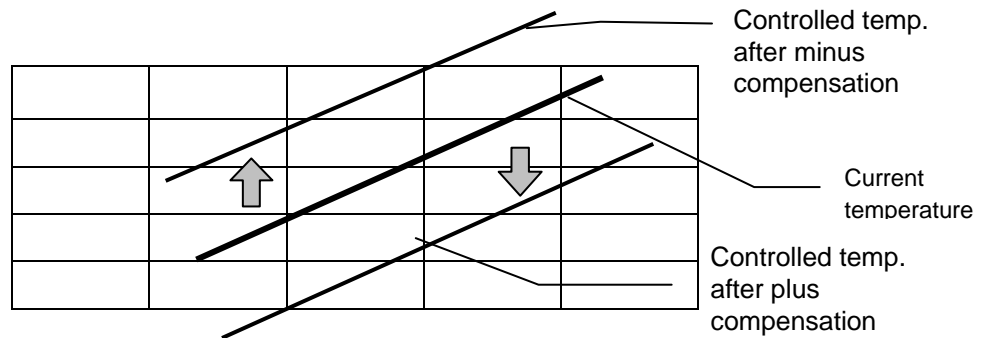

- ① Start operation at the target set temperature, and after the temperature has become stable, check the temperature in the bath with a temperature recorder.
 - ② Check difference between the set temperature and the temperature in the bath.
 - ③ Press the **TIMER** key longer to switch to the MAINTENANCE menu mode. (You are already in the MAINTENANCE menu mode if LOCK **LocFi** indication appears.)
Press the **TIMER** key several times to select the character **cAL** **cAL** that indicates the calibration offset function.
 - ④ Enter the difference between the set temperature and the temperature in the bath using the **▼▲** keys to complete setting.
- ※ Offset temperature may be set to either of + or – side.
Setting to the – side will decrease the displayed measured temperature by the offset amount while the temperature in the bath will increase by the same amount.
Setting to the + side will increase the displayed measured temperature by the offset amount while the temperature in the bath will decrease by the same amount.

Note : Temperature in the bath changes tentatively immediately after placing a specimen. Therefore, wait until the temperature in the bath become stable before checking for a temperature difference.

4. Operating procedures

Useful functions (setting key lock function)

The function is to lock the settings during operation for safety. You can set or release this function with the **MAINTENANCE** key.

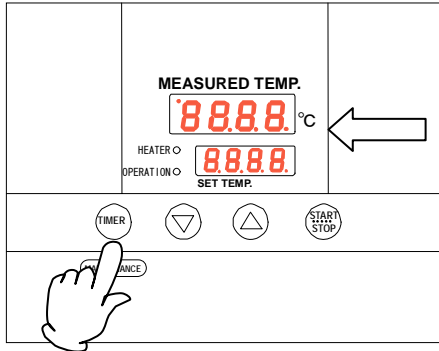

- ① Press the **TIMER** key longer to switch to the MAINTENANCE menu mode.

Press the **TIMER** key to select the character Lock **Loch** that indicates the settings lock.

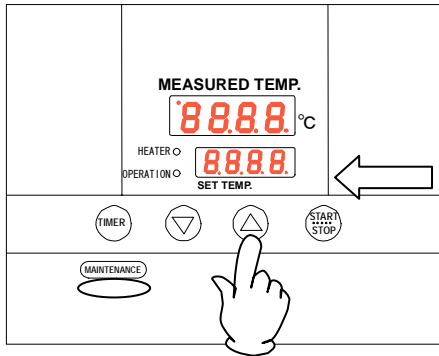

- ② "oFF" will appear in the SET TEMP screen. You can switch this to "on" with the ▲ key to lock the settings.

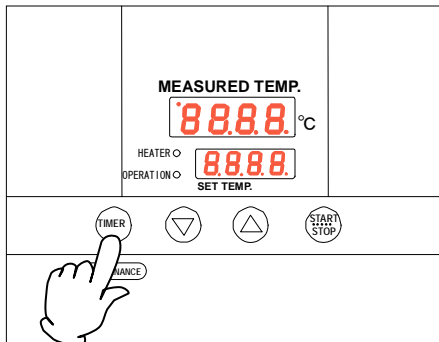

- ③ If you want to cancel lock, press the **TIMER** key longer again and select the character Lock **Loch** that indicates the setting lock using the ▼▲ keys. Selecting "oFF" with the ▼ key releases the lock.

※ While the lock function is "on", any keys other than the **START/STOP** key and **TIMER** key are locked.

4. Operating procedures

Useful functions (Using the service outlet)

Using the service outlet (Model IC101W only)

Model IC101W has a useful service outlet to which a device up to 2 amperes can be connected. This outlet can be used as a power supply for a small stirrer or other device that can be installed on the IC101W.

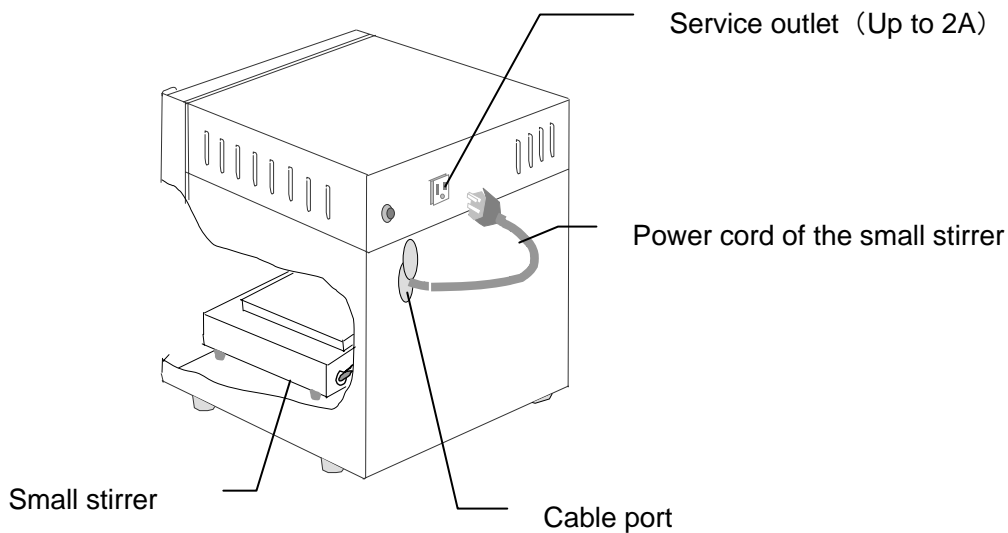

Operational precautions

- When a small stirrer has been installed, operate the unit at 45°C or lower set temperature to protect the stirrer.
- When a device that generates heat has been installed, proper temperature control may not be possible.
If this occurs, stop using that device.
- Install an optional stirrer stand with slide rail if you want to install a small stirrer.
- The bottom surface and walls in the bath will hot and avoid putting specimen directly on the bottom surface or allow them to touch with the side surface.

5. Handling precautions



1. About materials that cannot be used



Never use an explosive material, a flammable material, or a material that contains such materials for this unit. They may cause an explosion or a fire. (See P.37 "List of dangerous materials".)

2. About banning of operation/solutions when an abnormality occurs



When smoke or strange odor is generated from this unit for some reason, immediate turn power of the unit off, shut the power supply off and ask inspection to your dealer, one of our sales offices, or the customer center. Leaving the unit as it is may cause a fire or an electrical shock. The user must not attempt a repair, which may cause a danger.



1. Do not put any object on the unit



Do not put any object on the unit. It might fall off and cause a personal injury.

2. During a thunder storm



When a thunder begins, immediately turn power of the unit off, shut the power supply off. Leaving the unit as it is might cause a malfunction or a fire from lightening.

3. When opening or closing the door



When opening or closing the door, do not put your hands or face close to the area (space) where the door moves.

The door might hit the hand or the face and cause an injury.

4. Banning of use of corrosive materials



Although inside the bath is made of SUS304 stainless steel, it might corrode from a strong acid. The door packing is made of silicone rubber. Take care it might corrode with acid, alkaline, oil, or halogen based solvent.

5. Operate the unit at an appropriate temperature



The operational temperature range is +5°C~60°C room temperature.

Never operate the unit at a temperature out of the operational temperature range.

6. Placement of specimen



The withstand load of a shelf board is 10kg. Do not put a specimen exceeding this limit.

Put two or more specimens dispersed.

Putting too many specimens may cause imperfect transmission of heat to them and prevent even heating. Make sufficient spaces between specimens.

5.Handling precautions



7. About recovery from a power failure



When power is recovered after stoppage from power failure during operation, the unit automatically returns to the state immediately before power failure and resume operation. Set the power failure compensation function of the sub menu functions OFF if you do not want to allow the unit to automatically resume operation. See P.23.

8. About stacking in two layers



You can stack the units up to two layers only using the special stacking fittings of optional accessories.



Never stack the units in three or more layers.

9.After installation



An earthquake or a shock may cause the unit fall over or move and personal injuries may result. Implement appropriate fall-over preventive measures for safety.

6. Maintenance procedures

Daily inspection/maintenance

Warning

- Be sure to pull out the power cord unless necessary before trying to do inspection and maintenance works.
- Start these works after the device has returned to the normal temperature.
- Never try to disassemble the unit.

Caution

- Wipe off any dirt with a tightly wrung soft cloth. Never try to clean the unit with benzene, thinner or scouring powder, or rub with a scrubbing brush. Deformation, degradation or discoloration may result.

7. When the unit is not to be used for a long time or when disposing

When the unit is not to be used for a long time or when disposing



Caution



Warning

<p>When the unit is not going to be used for a long time</p> <ul style="list-style-type: none"> ● Turn the power to off and pull out the power cord. 	<p>When disposing the unit</p> <ul style="list-style-type: none"> ● Do not leave the unit in the area where children may have access. ● Be sure to remove handles before disposing the unit to prevent the doors from locking. ● In general, dispose the unit as a bulky waste.
---	--

Notes about disposition

Always pay attention to the preservation of the global environment.

- We highly recommend taking the unit apart as far as possible for separation or recycling to contribute to the preservation of the global environment. Major components and materials for the unit are as follows:

Names of major components	Major materials
Major components	
Chassis	Steel sheet iron, melamine resin baking finish
Interior	Stainless steel SUS304
Observation window (only IC101W)	Reinforced glass, Silicon rubber
Insulating material	Glass wool
Door packing	Silicon rubber
Nameplates	Polyethylene (PET) resin film
Major electric parts	
Heater	SUS—Chrome heater
Boards	Resin, board, condenser, resistor, transformer, or other composite parts
Power cord & wiring materials, etc.	Wiring materials with resin cladding

8. When a trouble occurs

Safety device and error codes

The table below shows the possible causes and solutions for a trouble and a safety device has activated.

[Error code]

When an operational abnormality or a malfunction occurs, "MALFUNCTION" sign and an error code will appear on the operation panel. When a malfunction occurs, note the error code and immediately stop operation.

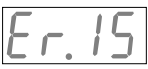
Safety device	Symptom	Possible causes and solutions
Wrong temperature input	Alarm lamp on  indication	<ul style="list-style-type: none"> Abnormal temperature input circuit Disconnection or malfunction of the temperature sensor The measured temperature is out of the display range. Contact the customer service center.
Malfunction of memory	Alarm lamp on  indication	<ul style="list-style-type: none"> Abnormal settings in memory Contact the customer service center.
Abnormal measured temperature	No indication	<ul style="list-style-type: none"> When the automatic overheat preventive device activated due to abnormal increase in temperature in the bath. Contact the customer service center.
Abnormal measured temperature	All function stop	<ul style="list-style-type: none"> When the independent overheat preventive device activated due to abnormal increase in temperature in the bath. Contact the customer service center.

About the activation of the circuit breaker (main switch)

The unit is equipped with a circuit breaker with the main switch function.

When excessive current flows through the unit for some reason, the circuit breaker will turn OFF (from I to O) and shut the power off. To recover, first remove the causes and then turn the switch ON again.

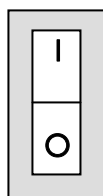

When the breaker activates, the switch returns from I to O.

8. When a trouble occurs

If a malfunction is suspected

In the following cases

Symptom	Possible Causes
The unit will not start even if power is turned on.	<ul style="list-style-type: none">● Power plug is not connected to the receptacle correctly.● Power failure.
Temperature changes during operation.	<ul style="list-style-type: none">● Too many specimens are placed.● Air from an air conditioner is blowing directly against.● Outside temperature is too low.● Changes in the environmental temperature are too large.● Specimen may contain too much water.● Source voltage may be too low.
There is a difference between the set temperature and the temperature in the bath.	<ul style="list-style-type: none">● The temperature compensation value of the calibration offset  may be too small or too large. Set the compensation to ± 0 once and wait until the temperature in the bath becomes stable (after about two hours), reenter the correct compensation value. (See P.24.)

- ◆When the symptom does not correspond to any of the above, immediately turn the power switch off, pull out the power plug and contact your dealer, one of our sales offices, or our customer service center.

9. After sales service and warranty

When requesting a repair

When requesting a repair

If any trouble occurs, immediately stop operation, turn the power switch off, pull out the power plug and contact your dealer, our sales office or our customer service center.

Information necessary for requesting a repair

- Model name of the product
 - Serial number
 - Date (y/m/d) of purchase
 - Description of trouble (as in detail as possible)
- } See the warranty card or the nameplate on the unit.
(See P.8~P.9) .

Be sure to indicate the warranty card to our service representative.

Warranty card (attached separately)

- Warranty card is given by your dealer or one of our sales offices and please fill in your dealer, date of purchase and other information and send it to our customer service center by Facsimile (03-3231-6523). Then, store it securely.
- Warranty period is one full year from the date of purchase. Repair service for free is available according to the conditions written on the warranty card.
- For repairs after the warranty period consult your dealer, one of our sales offices or our customer service center.
Paid repair service is available on your request when the product's functionality can be maintained by repair.

Minimum holding period of repair parts

The minimum holding period of repair parts for this product is seven years after end of production. Repair parts here refer to parts necessary for maintaining performance of the product.

10. Specifications

Specification of the main unit

Product name		Incubator	
Model		IC101 w	IC101
System		Internal bath wall heating natural convection system	
Construction	Exterior material	Steel plate, melamine baked finishing	
	Interior material	Stainless steel	
	Heater	Silicon code heater:100W	
	Cable hole	Inner dia. 30 ϕ x 1	
	Observation window	290W x 240H Dual semi-reinforced glass	
	Service outlet	An outlet 3P Max 2A	
Performance	Operation temperature range	Room temperature of +5°C to 60°C	
	Temperature control precision	$\pm 0.5^{\circ}\text{C}$ (at37°C)	
	Temperature distribution precision	$\pm 1.5^{\circ}\text{C}$ (at37°C)	$\pm 1.0^{\circ}\text{C}$ (at37°C)
	Time to attain the max. temperature	Approx. 40 minutes	
Temperature controller			
Control	Controller	PID control, digital setting	
	Temperature sensor	K-thermocouple	
	Temperature control system	PID control by micro computer	
	Temperature setting system	Up/Down key	
	Timer resolution	1 minute (0 hour 00min—99 hours 59mins) Setting by 1 minute up to 99 hours 59mins Setting by 10 minutes from 100 hours	
Safety function	Temp. controller alarm function	Automatic overheat prevention function : Set temperature +6°C main relay shut-off (Auto recovery)	
	Overheat prevention unit	Manual recovery bimetal (70°C)	
	Main switch	Circuit breaker(locker switch type)	
Operation function		Operation functions: fixed value, quick auto stop, auto stop, auto start Functions: operation key lock, calibration offset, power failure compensation	
Standard	External dimension	410 x 380 x 520	
	Internal dimension	350 x 300 x 360	
	Capacity	37L	
	Power supply	AC100V 50/60Hz 3.1A Service outlet 2A included	AC100V 50/60Hz 1.1A
	Power cord	3P cord with plug	
	Weight	Approx.17Kg	Approx.16kg
Accessories		2 sets of shelf boards(One is fixed in the bath), operating instruction, warranty card	
Optional parts			
		Stacking fittings	
		Set of shelf boards	
		Stirrer stand with slide rail (IC101 w only)	

* Performance is measured with the power of AC100V.

* The operation temperature range of the unit is 5°C~35°C. Note that a lower environmental temperature may prolong temperature attainment time or enlarge difference between set temperature and that in the bath. We recommend using the unit at the environmental temperature of 18°C~30°C.

* **External dimensions exclude protruding parts.**

11. Wiring Diagram

Wiring diagram
(IC101/IC101W)

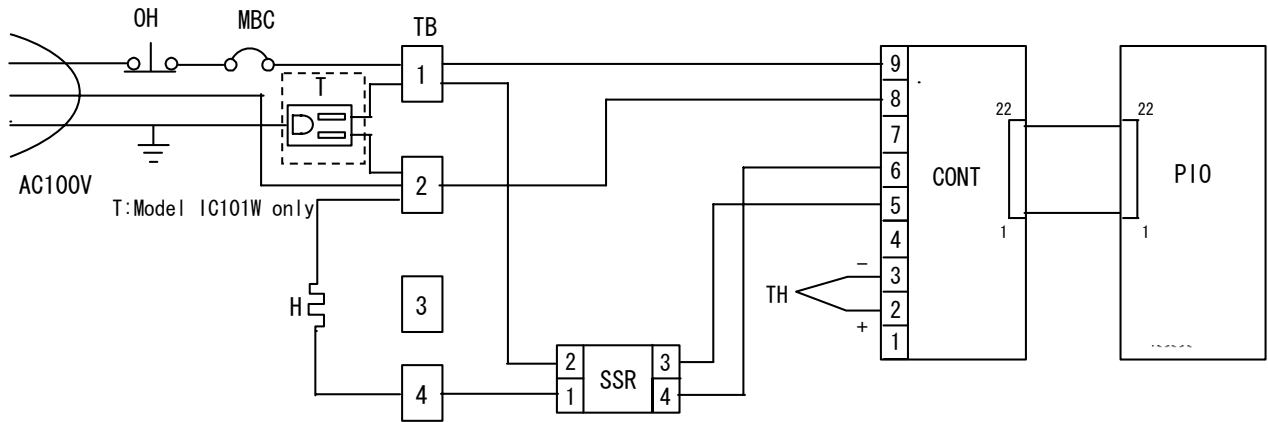

Model IC101 does not have a service outlet.

Symbol	Part name	Symbol	Part name
MCB	Main switch (Circuit breaker)	TC	Temperature controller
H	Cord heater	TH	K sensor for control
TB	Terminal block	OH	Overheat preventive bimetal
T	Service outlet (IC101w only)	SSR	Contact less relay

12. List of replacement parts

Replacement parts for IC101/IC101W

	Part Name	Specification	Manufacturer	Code No.
1	Control board for temperature controller	CN40BY-IC	Yamato Scientific	LT00007640
2	display board for temperature controller	CN40BY-IC	Yamato Scientific	LT00007639
3	K sensor for control	φ 0.32 K-thermocouple, with protective tube	Yamato Scientific	LT00009502
4	SSR	TRS5225	Toho Denshi	2160000035
5	Power cord kit	1.25sq3Pwith plug 2 m	Yamato Scientific	LT00001745
6	Circuit breaker	3130-F110 10A	ETA components	LT00001299
7	Overheat preventive device	Manual recovery bimetal 70°C	Matsuo electric	LT00002216
8	Cord heater	Silicon cord heater 100W	Yamato Scientific	LT00020099
9	Terminal block	TBF-250ABC-4P	Sakazume electric	LT00002219
10	Service outlet	S-150 125V 15A	Sato parts	LT00002360

13. List of dangerous materials



Never use an explosive substance a flammable substance or a substance containing them for this device.

Explosive substance	Explosive substance	① Nitroglycol, glycerine trinitrate, cellulose nitrate and other explosive nitrate esters
		② Trinitrobenzen, trinitrotoluene, picric acid and other explosive nitro compounds
		③ Acetyl hydroperoxide, methyl ethyl ketone peroxide, benzoyl peroxide and other organic peroxides
Flammable substances	Explosive substances	Metal "lithium", metal "potassium", metal "natrium", yellow phosphorus, phosphorus sulfide, red phosphorus, celluloids, calcium carbide (a.k.a, carbide), lime phosphide, magnesium powder, aluminum powder, metal powder other than magnesium and aluminum powder, sodium dithionous acid (a.k.a., hydrosulphite)
	Oxidizing substances	① Potassium chlorate, sodium chlorate, ammonium chlorate, and other chlorates
		② Potassium perchlorate, sodium perchlorate, ammonium perchlorate, and other perchlorates
		③ Potassium peroxide, sodium peroxide, barium peroxide, and other inorganic peroxides
		④ Potassium nitrate, sodium nitrate, ammonium nitrate, and other nitrates
		⑤ Sodium chlorite and other chlorites
		⑥ Calcium hypochlorite and other hypochlorites
	Flammable substances	① Ethyl ether, gasoline, acetaldehyde, propylene chloride, carbon disulfide, and other substances with ignition point at a degree 30 or more degrees below zero.
		② n-hexane, ethylene oxide, acetone, benzene, methyl ethyl ketone and other substances with ignition point between 30 degrees below zero and less than zero.
		③ Methanol, ethanol, xylene, pentyl acetate, (a.k.a.amyl acetate) and other substances with ignition point between zero and less than 30 degrees.
④ Kerosene, light oil, terebinth oil, isopenthyl alcohol(a.k.a. isoamyl alcohol), acetic acid and other substances with ignition point between 30 degrees and less than 65 degrees.		
Combustible gas	Hydrogen, acetylene, ethylene, methane, ethane, propane, butane and other Substance which is a flammable gas at 15°C, one air pressure.	

(Quoted from the separate table 1 in Article 6, the enforcement order of the Industrial Safety and Health Law

Limited liability

Be sure to use the unit strictly following the handling and operating instructions in this operating instruction.

Yamato Scientific Co.,Ltd. assumes no responsibility for an accident or a malfunction caused by use of this product in any way not specified in this operating instruction.

Never attempt to perform matters prohibited in this operation instruction.

Otherwise, an unexpected accident may result.

Notice

- **Descriptions in this operating instruction are subject to change without notice.**
- **We will replace a manual with a missing page or paging disorder.**

Operating instruction

Incubator

IC101/IC101W

3rd edition 1 August, 2007

Revised 22 February, 2012

Yamato Scientific Co.,Ltd.

〒103-8432

2-1-6, Nihonbashi, Honcho, Chuo-ku, Tokyo

Customer Service Center



Toll free: 0120-405525

<http://www.yamato-net.co.jp>